

■ The Company

A Strategic Alliance between Nacional Safety Valves and BS&B Pressure Safety Management

One of the most expansive markets to be found in the world today revolves around protecting industrial processes from damages caused by overpressure. To better serve this important need, the industry leaders of Nacional Safety Valves and BS&B Pressure Safety Management have teamed together to provide a “total solution approach” to overpressure relief needs. Through a strategic alliance, Nacional Safety Valves and BS&B Pressure Safety Management offers a variety of overpressure relief devices including safety valves, buckling pin valves, and rupture disk devices. The two companies will continue to operate as separate entities.

Both Nacional Safety Valves and BS&B Pressure Safety Management are established companies with decades of overpressure protection experience. Nacional has been designing and producing safety valves according to most recognized international standards for over four-decades. BS&B Pressure Safety Management has proven itself as a leading supplier of overpressure relief devices with a comprehensive portfolio of products and services that meet and exceed rigorous industry standards for quality and reliability.



As part of the strategic agreement established in 2017, BS&B Pressure Safety Management offers spring-loaded pressure relief valves manufactured by Nacional, under the combined brand name, “Nacional BS&B”. Nacional distributes a portfolio of overpressure relief devices supplied by BS&B Pressure Safety Management including rupture disk devices, safety relief valves, buckling pin valves, flame arresters, explosion protection, and wireless instrumentation.

About BS&B Pressure Safety Management

BS&B Pressure Safety Management is a solution provider company dedicated to supplying safety devices and systems according to customer defined application conditions. The company’s rich history spans more than 80-years with the BS&B name being well known for its innovative solutions in personal and property protection against dangerous overpressurizations and explosions within industrial settings. BS&B’s integrated solutions have been time tested and fine-tuned to deliver maximum value and greater efficiencies to individual engineering processes.



About Válvulas Nacional

VALVULAS NACIONAL, S.A. was established in Spain in 1976. The main target was to provide safety relief valves to the petrochemical and chemical industries emerging in Spain at that time. VALVULAS NACIONAL, S.A., has been designing and producing safety valves according to most recognized international standards and certifications: API 526 & 527, ASME B16.34 & ASME VIII DIV. 1, NB “UV” Stamps, ASTM and the European Directives 2014/68/EU (PED), PED Module B+D, 24/34 EU (ATEX), TR – CU, GOST U, and GOST TDS. The production process is accredited by ISO 9001.



■ Index

• GENERAL FEATURES	4
NAMEPLATE	5
• OPERATION	5
CONSTANT BACK PRESSURE OPERATION	6
VARIABLE BACK PRESSURE OPERATION	6
• CODIFICATION SYSTEM	7
• PART LIST	8
• BILL OF MATERIALS	9
• ACCESSORIES	11
• GENERAL DIMENSIONS	12
• TECHNICAL INFORMATION	14
OPERATING CHARACTERISTICS TABLE	14
CALCULATION FORMULAS FOR ORIFICE AREA	15
CONSTANTS	16
VALUES OF K AND C	16
CORRECTION COEFFICIENTS CHARTS	17
GASES DISCHARGE FLOW	18
STEAM DISCHARGE FLOW	19
LIQUIDS DISCHARGE FLOW	20
API SELECTION CHART	21
REACTION FORCES DURING DISCHARGE	28
NOISE DISCHARGE CALCULATION	28
• DEFINITIONS (ASME PTC-25)	30

■ General features

The Model 6400 is an angular type safety valve at 90° between the inlet and the outlet connections. It has flanged connections, a full nozzle, direct action and is spring loaded. There are three types: Conventional, Balanced (with bellows) and Balanced-Piston. All three are designed with specific trims to work with gases, steam and liquids.

DESIGN

- The valve body is angular type at 90° between the inlet and outlet flanges. Its large internal capacity and smooth internal body reduces turbulence.
- Full nozzle type, guided and screwed to body, enabling precise alignment and easy disassembly.
- Disc is separate from disc-holder, and a greater selection of materials can be offered.
- Stem-push rod design in two parts, enables push rod material to be hardened to withstand high pressure, facilitating displacement, minimizing seizure with the guide.
- The guide has a large push rod area to prevent damage, ensuring precise alignment with all internal components.
- The bellows are made so its average area is equal to orifice area. This achieves precise valve balance and excellent operation with variable back pressures. The bellows' design enables valve operation at maximum pressures and temperatures.
- Springs are designed with a highly reliable calculation software, and manufactured with the correct material of construction for the process conditions, ensuring accurate valve opening.
- The standardization of different valve types enables a conventional valve to be converted to a balanced bellow or balanced piston valve with only a minimal change of parts.

SIZES AND RATINGS

Standard sizes and ratings:

ASME:	
Sizes:	¾"x1¼" up to 12"x16"
Rating:	150# up to 2500#
EN/ISO:	
Sizes:	DN-20xDN-32 up to DN-150xDN-250
Rating:	PN-16 up to PN-40

CODES AND STANDARDS

Valves have been designed and manufactured in compliance with the following directives, codes and standards

Design:	ASME VIII DIV.1 / API-526 / EN ISO 4126-1 / AD 2000-Merkblatt A2
Tests:	ASME B16.34 & API-527
Pressure and Temperature Limits:	ASME B16.34 & EN 1092-1
Materials:	ASME / ASTM & EN
Certifications:	PED MODULE B+D / AD 2000-Merkblatt A2
Quality system:	EN ISO 9001:2008
European Directive:	97/23/CE (PED)
European Directive:	94/9/CE (ATEX)

- This catalogue reflects standard valves and operations. Upon request, our technical department can design for special applications.
- The safety valve is an automatic direct action device whose function is to relieve excessive overpressures in the installations that it protects. Its main operation is to allow sudden fluid discharge with a complete and fast opening (pop).
- The automatic valve opening is produced because of the additional push provided by the overpressure of the fluid itself, overcoming spring resistance. Once the installation has recovered to its normal service conditions, the valve closes again.
- Safety valve behavior is different according to whether the fluid it works with is in a single phase (gas or liquid only), or in two or more (multiple) phase conditions.

NAMEPLATES EN ISO 4126-1/ASME VIII DIV.1



■ Operation

The safety valve protects a pressurized installation. It remains closed until the force exerted by the pressure of fluid P_1 , against the disc, is equal to the force of spring F_r (Fig.1). From this point of equilibrium, the disc holder comes away the nozzle, releasing a small amount of fluid, (valve set pressure) which is applied in the ring chamber (C) formed between the disc holder and adjusting ring (Fig. 2). Chamber pressurization (C) creates an additional force contributing to total instantaneous valve opening (Fig.3). Maximum valve lift shall be achieved without the installation exceeding 10% of overpressure, regardless of whether fluid is a gas or liquid.

Once the overpressurization has dissipated, the pressure will reduce to a certain value below the set pressure, a closing the valve. The difference between set pressure and re-seating pressure (blowdown), may be between 7% and 15% depending on whether the valve is designed for a gas or liquid.

Overpressure and blowdown values may be corrected by positioning the adjusting ring closer to or further from, the internal disc holder surface.

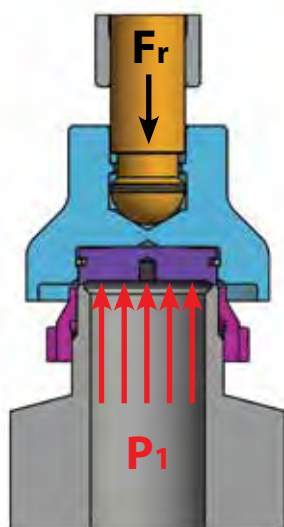

Fig.1

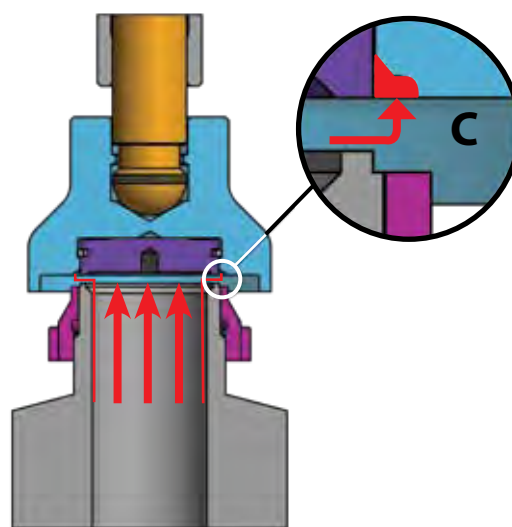

Fig.2

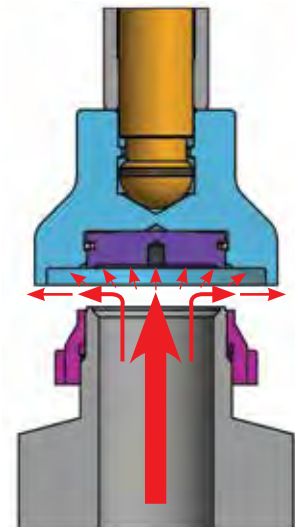

Fig.3

OPERATION AT CONSTANT BACK PRESSURE

When a conventional safety valve (without bellows) Model 64GC, is installed where the outlet of the valve has a constant (back) pressure applied (P_2), the back pressure must be taken into account. This back pressure influences the upper and lower disc holder surface, remaining balanced except for the area occupied by the inlet orifice (S_a), (where the back pressure does not act upon.) This results in additional force added to the spring. When adjusting the valve pressure on the test bench, one must subtract the back pressure (P_2) from the set pressure (P_1).

OPERATION AT VARIABLE BACK PRESSURE

If conventional valve Model 64GC discharges fluid where the back pressure is variable, then the set pressure is affected by the same variation. If this variation is greater than 10% of the set pressure, a balanced valve (with bellows) Model 64GF must be installed. The bellows function is to eliminate effects caused by back pressure.

The bellows mean diameter area (S_f), equals the valve inlet orifice area (S_a). It isolates the disc holder upper surface from back pressure action, setting it to atmospheric pressure through the vent hole in valve bonnet. Additional forces on the spring are eliminated. When the valve set pressure is adjusted on the test bench, no back pressure correction is required.

BACK PRESSURE EFFECT

When the valve opens under back pressure due to build-up of back pressure or superimposed back pressure, two conditions occur. It prevents the valve from achieving total lift without exceeding 10% overpressure. The force on the upper disc holder surface, and pressure reduction on the lower disc holder surface are eliminated. Back pressure data indicated on the operation technical characteristics tables are experimental back pressures performed in a laboratory on different valve types, and at no time exceed the maximum overpressure of 10%.

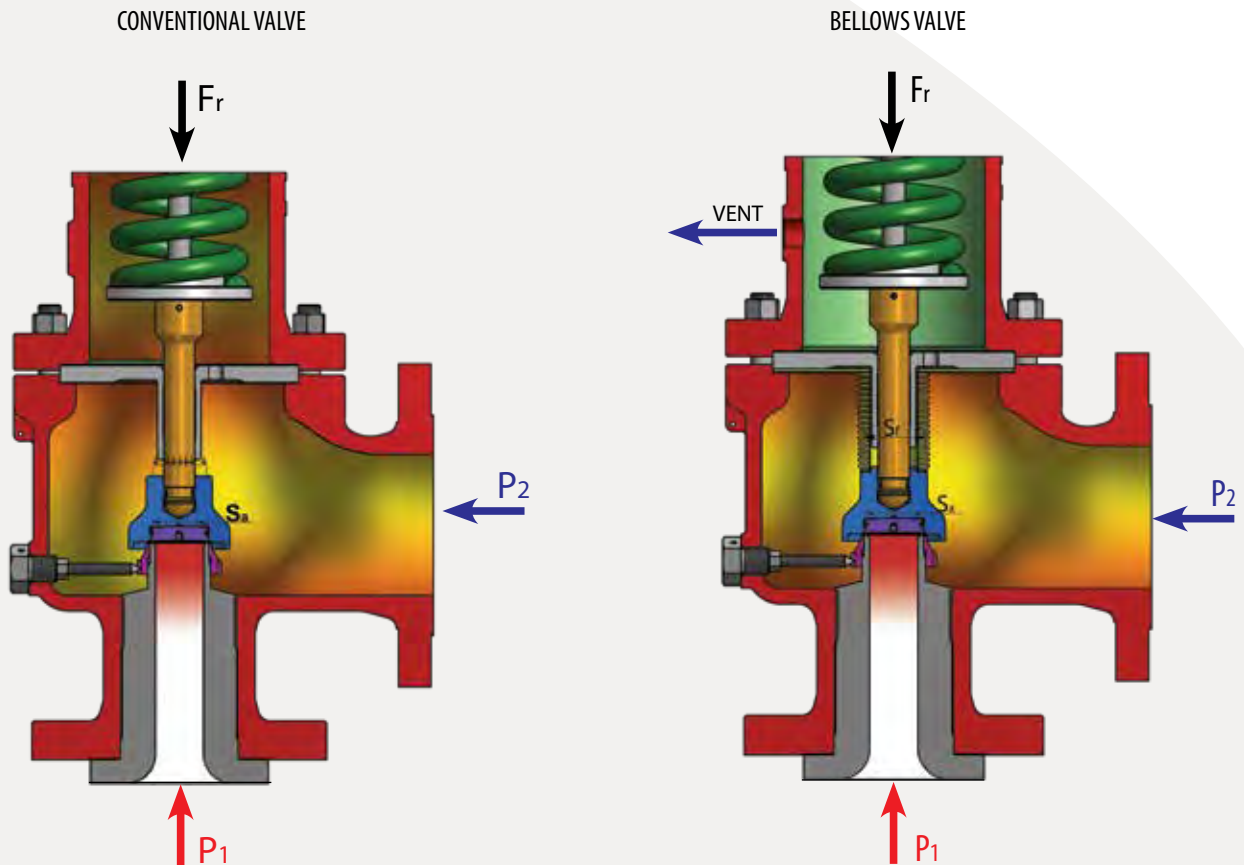

■ Codification system

64	G	C	2	J	3	2	1	A	2	XO
1 st	2 nd	3 rd	4 th	5 th	6 th	7 th	8 th	9 th	10 th	11 th

1st DIGIT: Valve model

2nd DIGIT: Work fluid state

G: Gas and Vapor

L: Liquid

3rd DIGIT: Valve type

C: Conventional

F: Bellows

P: Bellows-Piston

4th DIGIT: Inlet nominal size

5th DIGIT: Orifice size

6th DIGIT: Outlet nominal size

7th DIGIT: Inlet rating

1: ASME 150 B: PN-16

2: ASME 300 C: PN-25

3: ASME 600 D: PN-40

4: ASME 900 E: PN-63

5: ASME 1500 F: PN-100

6: ASME 2500 G: PN-160

A: PN-10 H: PN-250

8th DIGIT: Outlet rating

(Same 7th Digit)

9th DIGIT: Standard quality materials

10th DIGIT: Material Subclass (Nozzle and Disc) - (see bill of materials)

11th DIGIT: Standards accessories

X0	Packed Lever
X1	Test Gag
X2	Packed lever + Test Gag
X3	Open Bonnet
X4	Open Bonnet + Test Gag
X5	Open Bonnet + Test Gag + Packed Lever
Y4	Plain Lever
Y5	Plain Lever + Test Gag
Z2	O Ring
Z4	Inconel® X-750 Spring
W1	Open bonnet + Packed lever
W4	Nozzle with "Stellite"
W5	Disc with "Stellite"
V0	Magnetic sensor

Inconel® is a trademark of Special Metals Corporation.

■ **Part list**

CONVENTIONALL VALVE

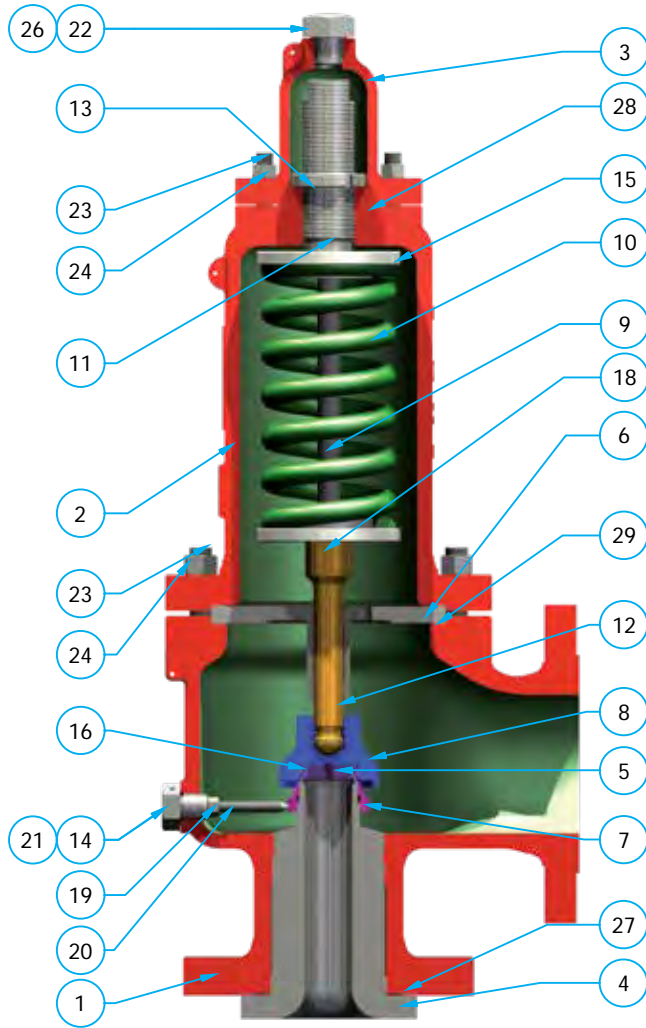

BELLOWS VALVE

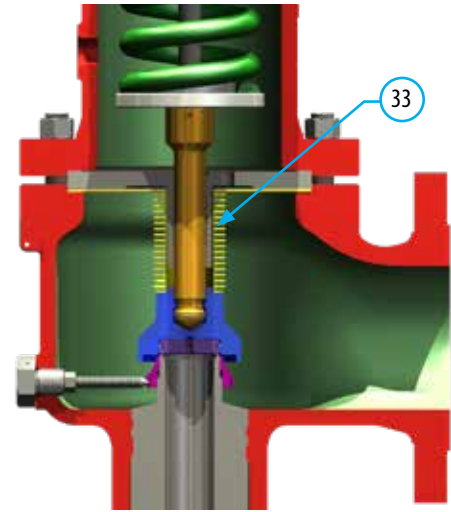

BELLOWS-PISTON VALVE

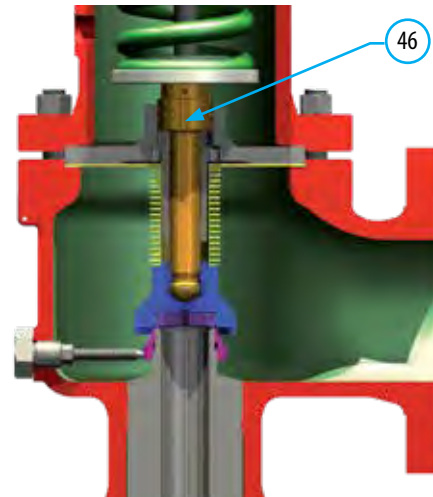

LEVER OPTION

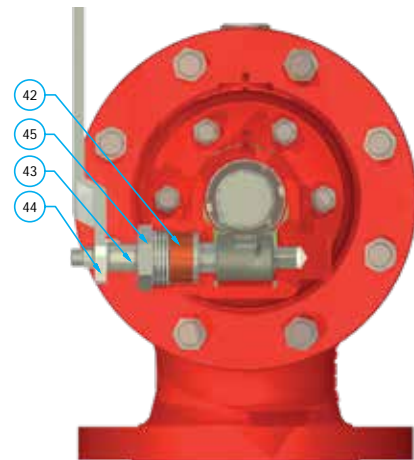
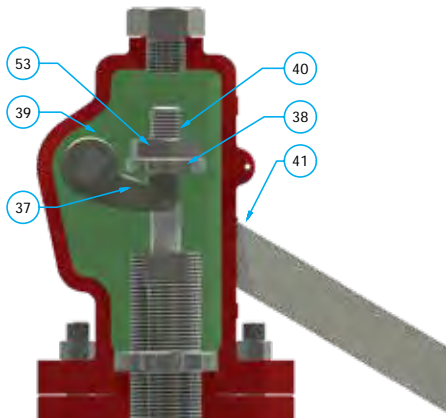

■ Bill of materials

CLASS		A	B	C	D	E	N1 (Duplex)	O (Super Duplex)	NACE - A
ITEM	DENOMINATION	-20 to 450 °F	451 to 797 °F	799 to 100 °F	-49 to 449 °F	-450 to 1000 °F	-20 to 500°F	-20 to 600°F	-20 to 797 °F
1	BODY	SA 216 WCB	SA 216 WCB	SA 217 WC6	SA 352 LCB	SA 351 CF8M	SA 995 CD4MCuN	SA 995 CD3MWCuN	SA 216 WCB
2	BONNET	SA 216 WCB	SA 216 WCB	SA 217 WC6	SA 352 LCB	SA 351 CF8M	SA 995 CD4MCuN	SA 995 CD3MWCuN	SA 216 WCB
2a	OPEN BONNET	SA 216 WCB	SA 216 WCB	SA 216 WCB	----	----	----	----	SA 216 WCB
3	CAP	SA 216 WCB (1)	SA 216 WCB (1)	SA 216 WCB (1)	SA 216 WCB (1)	SA 351 CF8M (1)	SA 351 CF8M (1)	SA 351 CF8M (1)	SA 216 WCB (1)
4	NOZZLE	SEE SUBCLASS							
5	DISC								
6	GUIDE	A 351 CF8M (2)	A 351 CF8M (2)	A 351 CF8M (2)	A 351 CF8M (2)	A 351 CF8M (2)	A 351 CF8M (2)	A 479 S32760 (17)	A 351 CF8M (2)
7	ADJUSTING RING	A 351 CF8M (3)	A 351 CF8M (3)	A 351 CF8M (3)	A 351 CF8M (3)	A 351 CF8M (3)	A 351 CF8M (3)	A 479 S32760 (17)	A 351 CF8M (3)
8	DISC HOLDER	A 479 431 (4) (6)	A 479 431 (4) (6)	A 479 431 (4) (6)	A 351 CF8M (2)	A 351 CF8M (2)	A 351 CF8M (2)	A 479 S32760 (17)	A 351 CF8M (2)
9	STEM	A 479 431 (5)	A 479 431 (5)	A 479 431 (5)	A 479 316	A 479 316	A 479 316	A 479 316	A 479 316
10	SPRING	50CRV4 C.S.	H21 T.S. (15)	H21 T.S. (15)	A 313 316	A 313 316 (11)	A 313 316 (11)	A 313 316 (11)	Inconel® X-750
11	ADJUSTING SCREW	A 479 431 (6)	A 479 431 (6)	A 479 431 (6)	A564 630	A564 630	A564 630	A564 630	A564 630
12	PUSH ROD	A 479 431 (6)	A 479 431 (6)	A 479 431 (6)	A 564 630 (10)	A 564 630 (10)	A 564 630 (10)	A 564 630 (10)	A 564 630 (10)
13	NUT	C.S. (7)	C.S. (7)	C.S. (7)	A 479 316	A 479 316	A 479 316	A 479 316	C.S. (7)
14	LOCK SCREW	C.S. (7)	C.S. (7)	C.S. (7)	S.S.	S.S.	S.S.	A 479 S32760 (17)	C.S. (7)
15	SPRING BUTTON	C.S. (7)	C.S. (7)	C.S. (7)	A 479 316	A 479 316	A 479 316	A 479 316	C.S. (7)
16	ELASTIC RING	316 S.S.	316 S.S.	316 S.S.	316 S.S.	316 S.S.	316 S.S.	316 S.S.	316 S.S.
17	PLUG	C.S. (7)	C.S. (7)	C.S. (7)	S.S.	S.S.	S.S.	A 479 S32760 (17)	C.S. (7)
18	ELASTIC PIN	302 S.S.	302 S.S.	302 S.S.	302 S.S.	302 S.S.	302 S.S.	302 S.S.	302 S.S.
19	NUT	316 S.S.	316 S.S.	316 S.S.	316 S.S.	316 S.S.	316 S.S.	A 479 S32760 (17)	316 S.S.
20	LOCK STUD	316 S.S.	316 S.S.	316 S.S.	316 S.S.	316 S.S.	316 S.S.	316 S.S.	316 S.S.
21	GASKET	Compressed Fibers	Graphite+316 S.S. (9)			Compressed Fibers (12)			
22	PLUG	C.S. (7)	C.S. (7)	C.S. (7)	S.S.	S.S.	S.S.	S.S.	C.S. (7)
23	STUDS	SA 193 B7 (7)	SA 193 B7 (7)	SA 193 B16 (7)(17)	SA 193 B8 (7)	SA 193 B8 (7)	SA 193 B8 (7)	SA 193 B8	SA 193 B7 (7)
24	NUTS	SA 194 2H (7)	SA 194 2H (7)	SA 194 4 (7)(17)	SA 194 G8 (7)	SA 194 G8 (7)	SA 194 G8 (7)	SA 194 G8	SA 194 2H (7)
26	GASKET	Compressed Fibers	Graphite+316 S.S. (9)			Compressed Fibers (12)			
27	GASKET	Compressed Fibers	Graphite+316 S.S. (9)			Compressed Fibers (12)			
28	GASKET	Compressed Fibers	Graphite+316 S.S.(9)			Compressed Fibers (12)			
29	GASKET	Compressed Fibers	Graphite+316 S.S. (9)			Compressed Fibers (12)			
33	BELLOWS	316Ti S.S. (8)	316Ti S.S. (8)	316Ti S.S. (8) (14)	316Ti S.S. (8)	316Ti S.S. (8) (14)	316Ti S.S. (8) (14)	316Ti S.S. (8)	Inconel® 625
34	GASKET	Compressed Fibers	Graphite+316316 S.S.(9)			Compressed Fibers (12)			

Inconel® is a trademark of Special Metals Corporation.

■ Bill of materials *continued*

CLASS		A	B	C	D	E	N1 (Duplex)	O (Super Duplex)	NACE - A
37	CAM	316 S.S.	316 S.S.	316 S.S.	316 S.S.	316 S.S.	316 S.S.	316 S.S.	316 S.S.
38	BRACKET	C.S. (7)	C.S. (7)	C.S. (7)	C.S. (7)	316 S.S.	316 S.S.	316 S.S.	C.S. (7)
39	LEVER CAP	SA 216 WCB	SA 216 WCB	SA 216 WCB	SA 216 WCB	SA 351 CF8M	SA 351 CF8M	SA 351 CF8M	SA 216 WCB
40	LEVER STEM	A 479 431 (5)	A 479 431 (5)	A 479 431 (5)	A 479 316	A 479 316	A 479 316	A 479 316	A 479 316
41	LEVER	C.S. (7)	C.S. (7)	C.S. (7)	C.S. (7)	C.S. (7)	C.S. (7)	C.S. (7)	C.S. (7)
42	PACKING	Compressed Fibers	Braid Graphite			Compressed Fibers (12)			
43	LEVER SHAFT	A 479 316	A 479 316	A 479 316	A 479 316	A 479 316	A 479 316	A 479 316	A 479 316
44	NUT	C.S. (7)	C.S. (7)	C.S. (7)	C.S. (7)	C.S. (7)	C.S. (7)	C.S. (7)	C.S. (7)
45	PACKING GLAND	C.S. (7)	C.S. (7)	C.S. (7)	C.S. (7)	S.S.	S.S.	S.S.	S.S.
46	PISTON	A 479 431 (6)	A 479 431 (6)	A 479 431 (6)	A 479 431 (6)	A 479 431 (6)	A 479 431 (6)	A 479 316	A 479 431 (6)
47	LOCK WASHER	304 S.S.	304 S.S.	304 S.S.	304 S.S.	304 S.S.	304 S.S.	304 S.S.	304 S.S.
53	NUT	C.S. (7)	C.S. (7)	C.S. (7)	C.S. (7)	S.S.	S.S.	S.S.	S.S.

SUBCLASS		1	2	3	4	10 (Duplex)	11 (Super Duplex)
4	NOZZLE	SA 479 316 (13)	SA 479 316+ST. (13)	SA 479 316+ST. (13)	SA 479 316 (13)	SA 479 S32550 (13)	SA 479 S32760 (13)
5	DISC	SA 479 316	SA 564 630 (10)	SA 479 316+ST.	SA 564 630 (10)	SA 479 S32550	SA 479 S32760

- | | |
|--|---|
| <p>(1) Models with inlet size 1" and 1 1/2", made of Carbon Steel or Stainless Steel bar</p> <p>(2) Models with inlet size 1" and 1 1/2", made of equivalent bar material</p> <p>(3) Orifices D-E-F, made of equivalent bar material</p> <p>(4) For Gas, orifices from M to T, made of equivalent casting material. For Liquid, orifices from P to T, made of equivalent casting material</p> <p>(5) Quenched and Tempered to 19 – 29 HRC, if necessary. Models with inlet size 1" and 1 1/2", Stem made of A 479 316</p> <p>(6) Quenched and Tempered to 45 – 50 HRC</p> <p>(7) Electrolytic bath, Zincate</p> <p>(8) Bellows endings made of 316L S.S.</p> | <p>(9) Graphite gasket with 316 S.S. reinforcement</p> <p>(10) H900 Condition, hardness must be between 40 – 47 HRC. For temperatures > -22°F. H1150-M Condition, hardness must be between 27 – 30 HRC. For temperatures < -22°F.</p> <p>(11) PaFor temperatures > 572°F, material Inconel® X-750 (Tempered)</p> <p>(12) For temperatures > 450°F and < -20°F, material Graphite with 316 S.S. reinforcement</p> <p>(13) Models with inlet size from 3" to 8", made of equivalent casting material</p> <p>(14) For temperatures > 842°F, material Inconel® 625</p> <p>(15) When the spring is unenclosed, carbon or alloy steel is used</p> |
|--|---|

Inconel® is a trademark of Special Metals Corporation.

■ Accessories

TEST-GAG

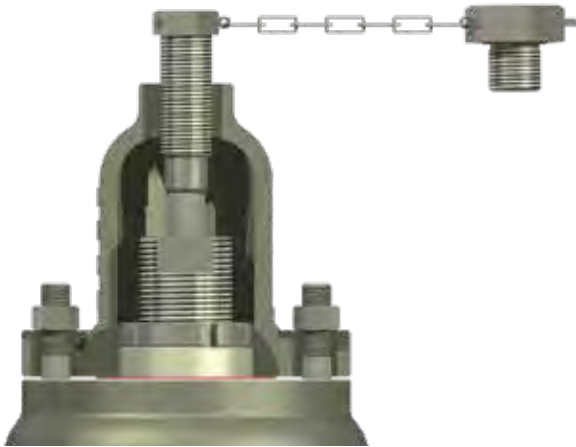

LEVER



O-RING

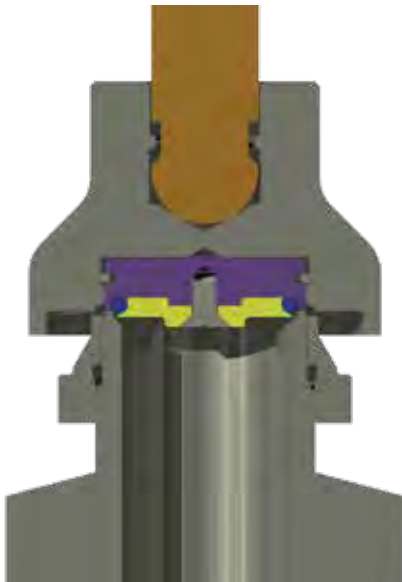

MAGNETIC SENSOR



HEATING JACKET

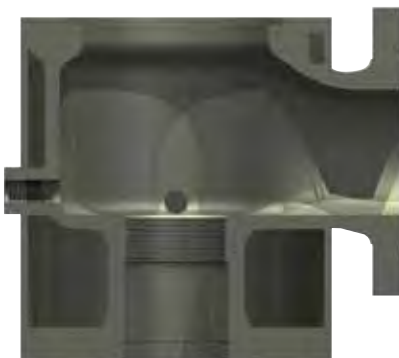

■ General Dimensions

"Orifice API 526"	Rating	Inlet	Outlet	Flow Area (in ²)	General Dimensions						Standard	Lever	
					A	B	C	D	E	F	Weight - (lbs)		
D													
	150 x 150	1"	2"	0.12	4.13	4.49	16.61	1.14	3.54	19.29	35.3	37.5	
	300L x 150							1.26					
	300 x 150							1.34					
	600 x 150	1½"	2"		5.51	19.37	1.73	21.89		68.3	72.8		
	900 x 300				5.51	7.01	20.39	2.36		22.91	86.0	90.4	
	1500 x 300												
	2500 x 300	1½"	3"	5.51	7.01	20.39	2.36	22.91	86.0	90.4			
E													
	150 x 150	1"	2"	0.22	4.13	4.49	16.61	1.14	3.54	19.29	35.3	37.5	
	300L x 150							1.26					
	300 x 150							1.34					
	600 x 150	1½"	2"		5.51	19.37	1.73	21.89		68.3	72.8		
	900 x 300				5.51	7.01	20.39	2.36		22.91	86.0	90.4	
	1500 x 300												
	2500 x 300	1½"	3"	5.51	7.01	20.39	2.36	22.91	86.0	90.4			
F													
	150 x 150	1½"	2"	0.35	4.88	4.76	17.68	1.34	3.54	22.17	57.3	59.5	
	300L x 150					5.98		1.46					
	300 x 150					1.61							
	600 x 150	1½"	3"		6.50	19.76	1.73	22.28		75.0	79.4		
	900 x 300				5.51	7.01	20.39	2.36		22.91	88.2	92.6	
	1500 x 300												
	2500 x 300	1½"	3"	5.51	7.01	20.39	2.36	22.91	88.2	92.6			
G													
	150 x 150	1½"	3"	0.56	4.88	4.76	19.65	1.34	3.54	22.17	59.5	63.9	
	300L x 150					5.98		1.46					
	300 x 150					1.61							
	600 x 150	2"	3"		6.50	19.76	1.73	21.89		77.2	81.6		
	900 x 300				6.14	6.77	25.31	2.24		3.94	27.52	123.5	130.1
	1500 x 300												
	2500 x 300	2"	3"	6.14	6.77	25.31	2.24	27.52	123.5	130.1	136.7		
H													
	150 x 150	1½"	3"	0.89	5.12	4.88	19.88	1.57	3.54	22.40	61.7	63.9	
	300L x 150							24.25					1.57
	300 x 150							25.20					1.73
	600 x 150	2"	3"		6.06	6.38	25.31	2.24		27.52	116.8	123.5	
	900 x 150				6.06	6.38	25.31	2.24		3.94	27.52	123.5	130.1
	1500 x 300												
	1500 x 300	2"	3"	6.06	6.38	25.31	2.24	27.52	123.5	130.1			
J													
	150 x 150	2"	3"	1.41	5.39	4.88	24.53	1.42	4.72	26.73	83.8	90.4	
	300L x 150							1.77					
	300 x 150							1.97					
	600 x 150	3"	4"		7.24	7.13	28.39	2.52		30.79	145.5	152.1	
	900 x 150				7.24	7.13	28.39	2.52		4.72	30.79	187.4	191.8
	1500 x 300												
	1500 x 300	3"	4"	7.24	7.13	28.39	2.52	30.79	187.4	191.8			
K													
	150 x 150	3"	4"	2.05	6.14	6.38	27.28	1.61	4.72	29.96	145.5	152.1	
	300L x 150							1.77					
	300 x 150							1.97					
	600 x 150	6"	6"		7.80	8.50	31.61	2.20		34.29	244.7	251.3	
	900 x 150				7.80	8.50	31.61	2.20		4.72	34.29	244.7	251.3
	1500 x 300												
	1500 x 300	6"	6"	7.80	8.50	31.61	2.20	34.29	244.7	251.3			
L													
	150 x 150	3"	4"	31.62	6.14	6.50	27.28	1.61	4.72	29.96	147.7	152.1	
	300L x 150							1.77					
	300 x 150							1.97					
	600 x 150	4"	6"		7.05	7.13	34.29	1.97		38.31	257.9	271.2	
	900 x 150				7.05	7.13	34.29	2.13		5.91	38.31	260.1	273.4
	1500 x 150												
	1500 x 150	4"	6"	7.05	7.13	34.29	2.13	38.31	260.1	273.4			
	1500 x 150	4"	6"	31.62	7.76	8.74	34.96	2.36	5.91	38.98	275.6	288.8	
	300L x 150							2.72					
	300 x 150							2.36					
	600 x 150	4"	6"		7.76	8.74	34.96	2.72		38.98	275.6	288.8	
	900 x 150				7.76	8.74	34.96	2.72		5.91	38.98	275.6	288.8
	1500 x 150												
	1500 x 150	4"	6"	7.76	8.74	34.96	2.72	38.98	275.6	288.8			

"Orifice API 526"	Rating	Inlet	Outlet	Flow Area (in ²)	General Dimensions						Standard	Lever	
					A	B	C	D	E	F	Weight - (lb)		
M													
150 x 150	4"	6"	6"	4.03	7.01	7.24	34.41	1.69	5.91	38.35	260.1	273.4	
300L x 150								1.97					
300 x 150								2.13					
600 x 150					7.76	8.74	34.96	2.36		38.98			
900 x 150													
N													
150 x 150	4"	6"	6"	4.99	7.76	8.27	34.69	1.69	5.91	38.70	260.1	273.4	
300L x 150								1.97					
300 x 150								2.13					
600 x 150					7.76	8.74	34.96	2.36		38.98			
900 x 150													
P													
150 x 150	4"	6"	6"	7.22	7.13	9.02	35.12	1.73	5.91	39.13	260.1	273.4	
300L x 150					8.86	10.00	36.06	2.01		40.08			
300 x 150								2.32					
600 x 150								2.56					
900 x 150													
Q													
150 x 150	6"	8"	8"	12.17	9.45	9.49	41.57	1.77	5.91	45.59	412.3	425.5	
300L x 150								2.20					
300 x 150								2.72					456.4
600 x 150													
R													
150 x 150	6"	8"	8"	17.52	9.45	9.49	41.57	1.77	5.91	45.59	421.1	434.3	
300L x 150								10.51					2.20
300 x 150													
600 x 150					522.5								
T													
150 x 150	8"	10"	10"	28.52	10.87	10.98	50.00	2.01	5.91	53.74	661.4	692.3	
300L x 150								2.56					694.5
300 x 150													
V													
150 x 150	10"	14"	14"	48.67	12.99	14.57	60.24	2.36	8.66	61.22	1135.4	1157.4	
300 x 150											1168.4	1190.5	
W													
150 x 150	12"	16"	16"	70.06	14.96	15.35	66.93	2.36	8.66	67.91	1554.3	1576.3	
300 x 150											1587.3	1609.4	

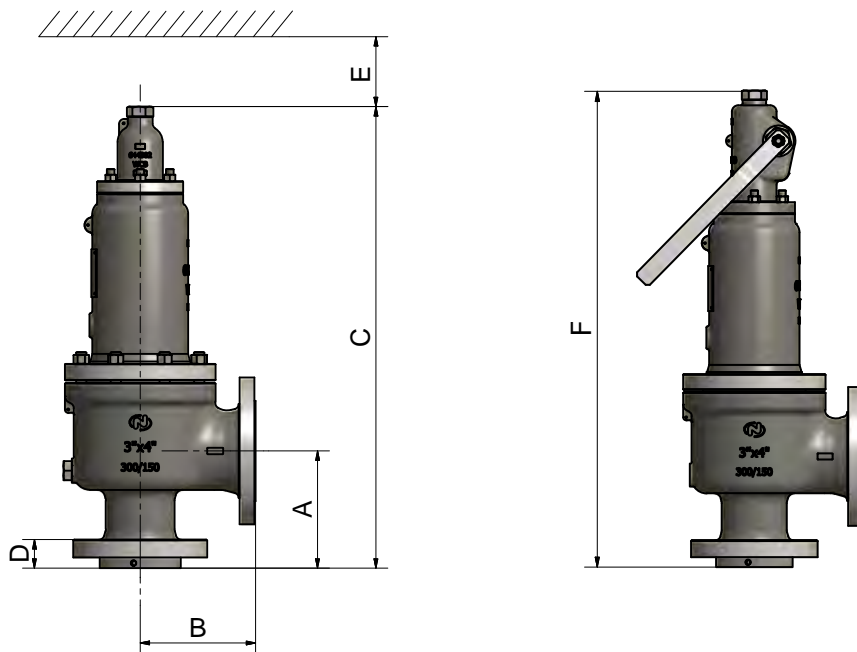

■ Technical information / Operating technical characteristics table

SAFETY VALVE MODEL 6400			64GC	64GF/64GP	64LC	64LF/64LP
			conventional	bellows	conventional	bellows
SERVICE			GAS		LIQUID	
DISCHARGE COEFFICIENT (at 10% of overpressure)	(1)(2)	Kd	0.97		0.80	
BLOWDOWN		MAX. MIN.	-7% (4) -2%		-20% (5) -12%	
SUPERIMPOSED BACKPRESSURE	(3)	MAX.	10%	25%	10%	40%
BUILT-UP BACKPRESSURE	(3)	MAX.	15%	40%	15%	50%
SET PRESSURE TOLERANCE	(6)	±	3%			
MINIMUM SET PRESSURE	ASME VIII (psig) EN ISO 4126-1 (psig)		14.5 7.25			

- (1) or 1.45 psig, whichever is greater
- (2) Certificate test in the National Board Testing Lab.
- (3) Maximum allowable backpressure without overpressure exceeds 10%
- (4) or 2.90 psig, whichever is greater
- (5) or 8.70 psig bar, whichever is greater
- (6) or ± 2.17 psig, whichever is greater

OPERATING VALVE GRAPHIC ON TEST BENCH WITH WATER:

MODEL: 64LF

SIZE: 2" x 3"

ORIFICE: J

SET PRESSURE: 81.22 psig

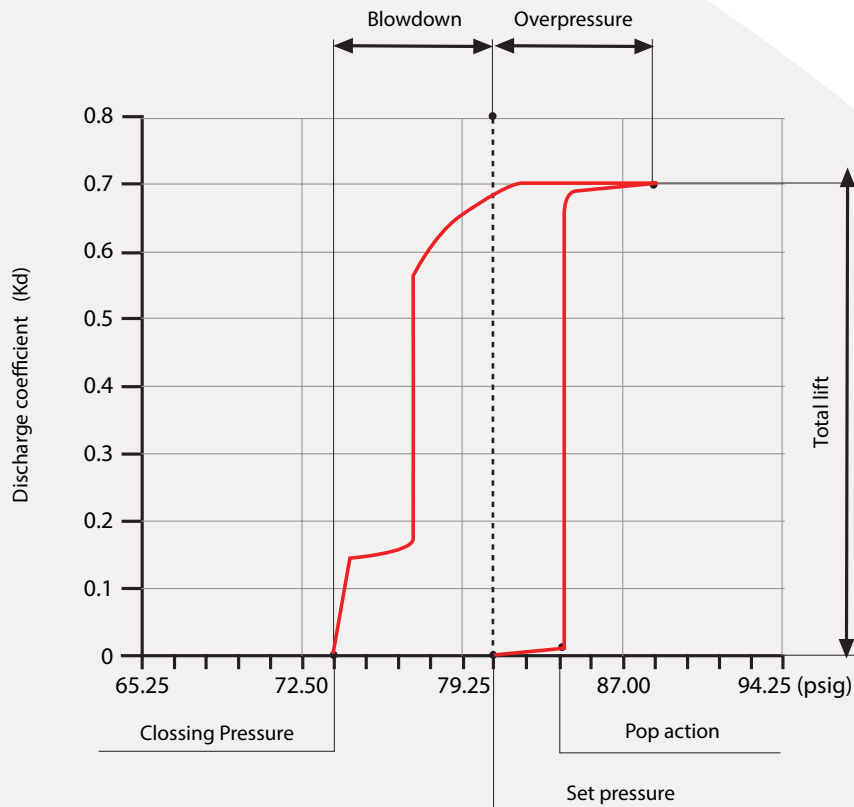

■ Technical information

Calculation Formulas for the Orifice Area

The following formulas determine the minimum area the safety valve should have to discharge the fluid flow requested

Liquids

$$A = \frac{W}{38 \cdot K \cdot K_3 \cdot K_v \cdot \sqrt{(P - P_b)} \cdot E}$$

Gases and Vapors

$$A = \frac{W}{C \cdot P \cdot K \cdot K_1 \cdot K_2} \cdot \sqrt{\frac{Z \cdot T}{M}}$$

Steam

$$A = \frac{W}{0.2883 \cdot C \cdot K \cdot K_1 \cdot K_2} \cdot \sqrt{\frac{V_1}{P}}$$

Discharge coefficient (K) for safety valves model 6400

Gases and Vapors	K=0.97
Liquids	K=0.80

Definition of calculation terms

Orifice area	A (in ²)
Discharge flow	W (lb/h)
Discharge pressure (set pressure + overpressure + 1.033)	P (lb/in ²) (a)
Set pressure	P1 (lb/in ²)
Back pressure	P2 (lb/in ²)
Back pressure abs.	Pb (lb/in ²)
Over pressure	S (%)
Relieving temperature	T (°K)
Compressibility factor at P and T (use 1 if unknow)	Z
Molecular weight	M
Expansion coefficient as function of (k)	C
Specific heats ratio (use k=1,001 if unknow)	k (cp/cv)
Vapor specific volume at T and T	V ₁ (ft ³ /lb)
Liquid specific gravity at P and T	E (lb/dm ³)
Liquid Vapor pressure at P and T	Pv (lb/in ²) (a)
Critical pressure	Pc
Discharge coefficient	K ₁
Correction coefficient by back pressure for conventional valves if Pb > 0,5P (gases and Vapors)	K ₂
Correction coefficient by back pressure for balanced valves if P2 > 0,3P1 (gases and Vapors)	K ₃
Correction coefficient by back pressure for balanced valves if P2 > 0,15P1 (liquids)	K _v
Correction coefficient for viscous liquids	K _p
Correction coefficient due to overpressure different to 25%	

■ Technical information / Constants

Constants of some fluids to be used on calculation formulas							
Fluids	M	k = cp / cv (1)	Specific Gravity		Critical Point		
			Gas	Liquid	Pressure	Temp.	Sp. Grav.
			Kg/Nm ³	Kg/dm ³	psig	°K	Kg/dm ³
Acetylene	26.04	1.26	1.171	0.613	920.2	308.9	0.231
Acetic Acid	60.05	1.15	2.681	1.049	839.2	594.8	0.351
Hydrochloric Acid	36.47	1.41	1.639		1223.2	324.6	0.61
Nitric Acid				1.502			
Sulfuric Acid				1.834			
Air	28.96	1.41	1.293	0.875	546.2	132.5	0.31
Ethyl Alcohol	46.07	1.13	2.057	0.789	925.9	516	0.28
Methyl Alcohol	32	1.2	1.429	0.792	1455	513	0.358
Ammonia	17.03	1.31	0.771	0.68	1638.5	405.6	0.235
Sulfhur Dioxide	64.06	1.29	2.922	1.434	1143.6	430.5	0.524
Argon	39.94	1.67	1.784	1.404	705.5	150.8	0.531
Venezene	78.11	1.12	3.487	0.879	705.5	561.8	0.305
Butane - n	58.12	1.09	2.703	0.6	529.1	426.4	
Butane - iso	58.12	1.1	2.668	0.595	536.2	406.9	
Chlorine	70.91	1.35	3.22	1.558	1116.5		0.573
Carbon Dioxide	44.01	1.3	1.977	1.101	1066.7	304	0.46
Dowtherm - A	165	1.05	7.365	0.997			
Ethane	30.07	1.19	1.356	0.546	719.7	308	0.21
Ethylene	28.05	1.24	1.261	0.568	745.3	282.7	0.216
Freon - 12	120.92	1.14	5.397	1.486			
Freon - 22	86.48	1.18	3.86	1.419			
Fuel Oil				0.899			
Natural Gas	19	1.27	0.853				
Gasoline				0.75			
Helium	4	1.66	0.179	0.125	33.1	5.3	0.069
Heptane - n	100.2	1.05	4.473		395.4	540.0	0.234
Hexane - n	86.17	1.06	3.847	0.659	438.1	508.0	0.234
Hydrogen	2.02	1.41	0.09	0.071	187.7	33.3	0.031
Kerosene				0.815			
Metane	16.04	1.31	0.717	0.415	671.3	190.7	0.162
Nitrogen	28.02	1.4	1.251	0.81	492.1	126.1	0.311
Octane - n	114.22	1.05	5.099	0.707	362.7	569.4	0.233
Nitrous Oxide	44.02	1.3	1.978	1.226	1052.5	309.7	0.46
Oxygen	32	1.4	1.429	1.131	731.1	154.4	0.43
Pentane - n	72.15	1.07	3.221	0.631	485	470	0.232
Propane	44.09	1.13	2.019	0.585	615.9	370.0	0.226
Carbon Disulphide	76.13	1.21	3.398	1.263	1102.3	550	0.441

(1) Values of k at 59 °F and ° Atm.

■ Technical information / Correction coefficient charts

Correction Coefficients r_c , K_1 , K_2 , K_3 , K_p

Correction Coefficient by back pressure for conventional valves K_1 (Gases and Vapors)

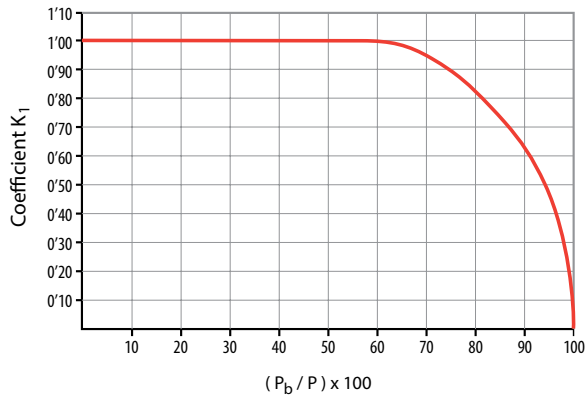

Critical pressure coefficient r_c (Water)

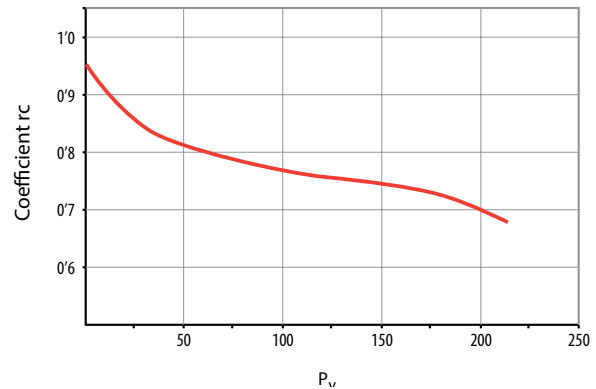

Correction Coefficient by back pressure for balanced valves K_2 (Gases and Vapors)

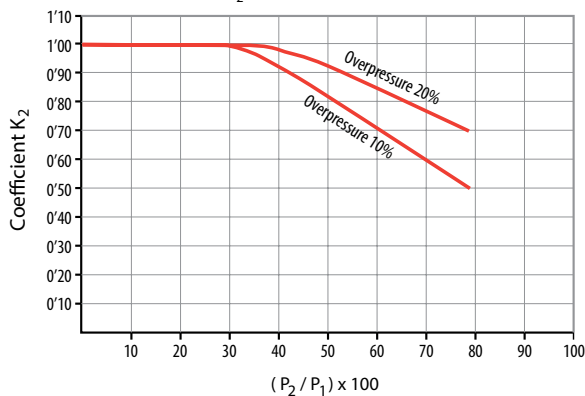

Critical pressure coefficient r_c (Liquids)

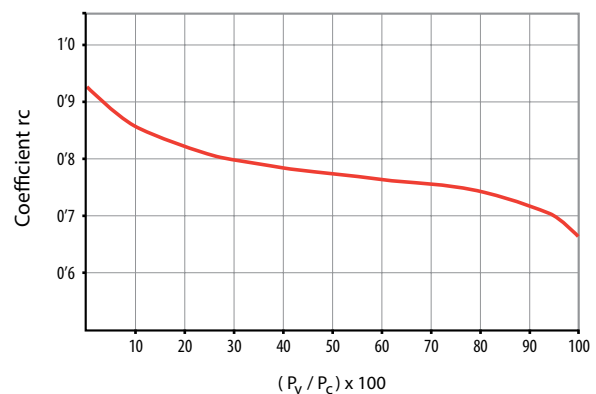

Correction Coefficient by back pressure for balanced valves K_3 (Liquids)

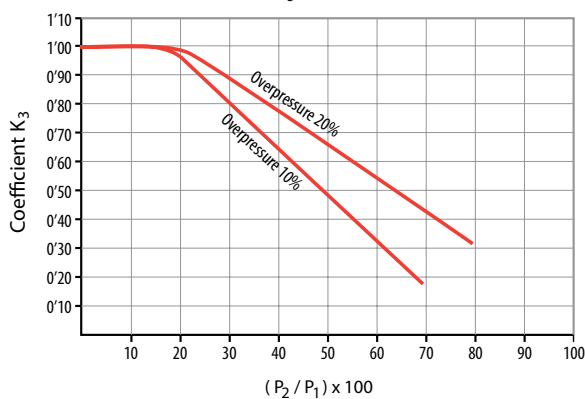

K_v Viscosity Correction Factor

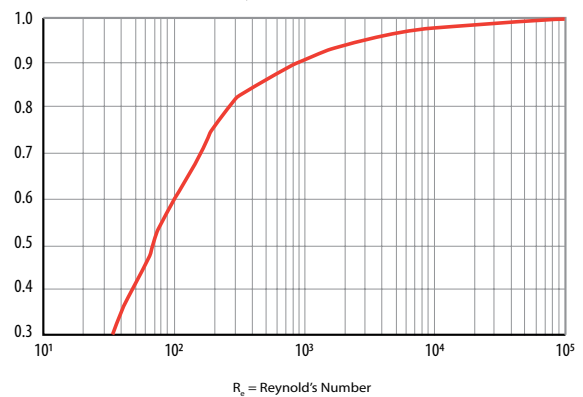

■ Gases discharge flow / Capacity chart - Air

$$A = \frac{W}{C \cdot P \cdot K \cdot K_1 \cdot K_2} \cdot \sqrt{\frac{Z \cdot T}{M}}$$

Flow		SCFH		Compressibility factor Z:				Temperature:				59° F			
Overpressure		10% (*)		Specific Heat Ratio K:				Discharge coefficient derated:				0.873			
P	D	E	F	G	H	J	K	L	M	N	P	Q	R	T	
psig	0.12	0.22	0.35	0.56	0.89	1.41	2.05	3.16	4.03	4.99	7.22	12.17	17.52	28.52	
5	2490	4565	7245	11585	18260	28950	42135	65115	82990	102780	148745	250570	360695	587325	
10	3040	5575	8850	14150	22300	35360	51465	79535	101365	125540	181680	306045	440550	717360	
15	3590	6585	10455	16720	26345	41770	60790	93950	119740	148295	214610	361525	520410	847395	
20	4145	7595	12060	19285	30385	48180	70120	108365	138115	171050	247545	417000	600270	977430	
25	4695	8605	13665	21850	34430	54590	79450	122785	156490	193805	280475	472480	680125	1107465	
30	5260	9640	15305	24470	38560	61145	88985	137525	175280	217075	314150	529205	761785	1240430	
35	5870	10750	17070	27295	43010	68195	99250	153385	195490	242105	350370	590230	849630	1383470	
40	6470	11865	18830	30115	47455	75245	109510	169245	215700	267140	386605	651255	937475	1526505	
45	7075	12975	20595	32935	51900	82300	119770	185100	235915	292170	422830	712280	1025320	1669545	
50	7685	14080	22360	35760	56350	89350	130035	200960	256125	317200	459055	773305	1113165	1812585	
60	8895	16310	25890	41405	65240	103450	150555	232680	296550	367265	531510	895355	1288850	2098660	
70	10110	18535	29420	47045	74135	117550	171080	264395	336975	417330	603960	1017400	1464540	2384740	
80	11320	20755	32950	52690	83030	131655	191600	296110	377400	467395	676415	1139450	1640230	2670815	
90	12535	22980	36480	58335	91920	145755	212125	327830	417820	517455	748865	1261500	1815920	2956895	
100	13745	25205	40010	63980	100815	159855	232650	359545	458245	567520	821320	1383550	1991605	3242970	
120	16175	29650	47065	75265	118600	188060	273695	422980	539095	667645	966220	1627650	2342985	3815125	
140	18600	34090	54125	86555	136385	216265	314740	486415	619940	767775	1111125	1871745	2694360	4387280	
160	21025	38545	61185	97840	154175	244470	355785	549850	700790	867900	1256030	2115845	3045740	4959435	
180	23450	42990	68245	109130	171960	272670	396830	613285	781640	968030	1400935	2359945	3397120	5531590	
200	25875	47435	75300	120415	189745	300875	437875	676720	862485	1068155	1545840	2604045	3748495	6103745	
220	28300	51885	82360	131705	207535	329080	478925	740155	943335	1168280	1690745	2848140	4099875	6675900	
240	30725	56330	89420	142990	225320	357280	519970	803590	1024180	1268410	1835650	3092240	4451250	7248055	
260	33151	60775	96480	154280	243105	385485	561015	867025	1105030	1368535	1980555	3336340	4802630	7820210	
280	35575	65225	103535	165565	260895	413690	602060	930460	1185875	1468665	2125455	3580440	5154005	8392365	
300	38000	69670	110595	176855	278680	441890	643105	993890	1266725	1568790	2270360	3824535	5505385	8964520	
350	44065	80785	128240	205075	323145	512400	745720	1152480	1468845	1819110	2632625	4434785	6383830	7262270	
400	50130	91905	145890	233290	367610	582910	848335	1311065	1670965	2069425	2994885	5045030	7262270		
450	56190	103020	163535	261510	412080	653420	950950	1469650	1873085	2319745	3357145	5655275			
500	62250	114135	181180	289730	456545	723925	1053565	1628240	2075205	2570060	3719405	6265525			
600	74380	136370	216475	346170	545480	864945	1258795	1945410	2479445	3070695	4443930	7486015			
700	86510	158605	251770	402605	634410	1005960	1464025	2262585	2883685	3571330	5168450				
800	98640	180835	287061	459045	723345	1146980	1669255	2579755	3287925	4071970	5892970				
900	110765	203070	322355	515485	812275	1287995	1874485	2896930	3692165	4572605	6617495				
1000	122890	225300	357650	571920	901210	1429015	2079715	3214100	4096405	5073240	7342015				
1100	135020	247535	392940	628360	990140	1570030	2284940	3531275	4500645	5573875	8066540				
1200	147150	269770	428235	684795	1079075	1711050	2490170	3848445	4904885	6074510	8791060				
1300	159275	292000	463525	741235	1168005	1852065	2695400	4165620	5309125	6575145					
1400	171400	314235	498820	797675	1256940	1993085	2900630	4482795	5713365	7075780					
1500	183530	336470	534115	854110	1345875	2134100	3105860	4799965	6117605	7576415					
1600	195655	358700	569405	910550	1434805	2275120	3311090	5117140	6521845						
1700	207780	380935	604700	966990	1523740	2416135	3516320	5434310	6926080						
1800	219910	403170	639995	1023425	1612670	2557155	3721550	5751485	7330320						
1900	232040	425400	675285	1079865	1701605	2698170	3926780								
2000	244165	447635	710580	1136300	1790535	2839190	4132005								
2100	256290	469865	745875	1192740	1879470	2980205	4337235								
2200	268420	492100	781165	1249180	1968400	3121225	4542465								
2300	280545	514335	816460	1305615	2057335	3262240	4747695								
2400	292670	536565	851755	1362055	2146265	3403260	4952925								
2500	304800	558800	887045	1418490	2235200	3544275	5158155								
2700	329055	603265	957635	1531370	2413065	3826310									
2900	353310	647735	1028220	1644245	2590930	4108345									
3100	377560	692200	1098805	1757120	2768795	4390380									
3400	413945	758900	1204685	1926435											
3700	450325	825600	1310565	2095750											
4000	486710	892300	1416445	2265065											
4300	523090	958995	1522325												
4600	559470	1025695	1628205												
4900	595855	1092395	1734085												

(*) Minimum overpressure 2.90 psig

It is recommended, if possible, selecting the orifice by applying the calculation formulas.

These tables can be useful when a quick estimation of the orifice is required.

Atmospheric pressure will be considered

■ Steam discharge flow / Capacity chart - steam

$$A = \frac{W}{0.2883 \cdot C \cdot K \cdot K_1 \cdot K_2} \cdot \sqrt{\frac{V_1}{P}}$$

Flow:	lbs/hr													
Overpressure:	10%													
Discharge coefficient derated:	0.873													
The results shown correspond to calculations for saturated steam														
For superheated steam, multiply by Ks														
Minimum overpressure 2.90 psig														
P1	D	E	F	G	H	J	K	L	M	N	P	Q	R	T
psig	0.12	0.22	0.35	0.56	0.89	1.41	2.05	3.16	4.03	4.99	7.22	12.17	17.52	28.52
5	5	120	195	310	490	775	1130	1745	2225	2755	3985	6715	9665	15740
10	100	185	295	475	750	1185	1725	2665	3400	4210	6090	10260	14770	24050
15	135	245	390	625	980	1555	2265	3500	4465	5530	8000	13475	19400	31585
20	165	300	480	765	1205	1910	2785	4300	5480	6790	9825	16550	23825	38795
25	195	355	565	905	1425	2260	3290	5080	6475	8020	11605	19550	28145	45825
30	225	410	650	1040	1640	2605	3790	5855	7465	9245	13380	22540	32445	52830
35	255	465	740	1185	1865	2955	4300	6645	8470	10490	15185	25575	36820	59950
40	285	520	820	1320	2085	3305	4810	7430	9470	11730	16975	28595	41160	67025
45	315	575	910	1460	2300	3650	5315	8210	10465	12960	18755	31595	45480	74055
50	345	630	1000	1600	2520	3995	5815	8985	11455	14185	20530	34580	49780	81060
60	405	740	1170	1875	2955	4680	6815	10530	13420	16620	24055	40520	58330	94980
70	460	845	1345	2145	3385	5365	7805	12065	15380	19045	27560	46430	66835	108825
80	520	955	1515	2420	3810	6045	8795	13595	17325	21455	31050	52310	75300	122610
90	580	1060	1680	2690	4240	6720	9780	15115	19265	23860	34530	58170	83735	136345
100	635	1165	1850	2960	4665	7395	10765	16635	21200	26260	38000	64015	92145	150045
120	750	1380	2190	3500	5515	8740	12725	19660	25060	31035	44915	75660	108915	177345
140	866	1590	2525	4035	6360	10085	14675	22680	28905	35800	51805	87270	125625	204560
160	980	1800	2860	4570	7205	11420	16625	25690	32740	40550	58685	98855	142305	231715
180	1095	2010	3195	5100	8045	12760	18570	28695	36575	45295	65550	110425	158955	258825
200	1210	2220	3525	5640	8890	14095	20510	31700	40400	50035	72410	121980	175590	285915
220	1325	2430	3860	6175	9730	15430	22455	34700	44225	54775	79265	133530	192215	312985
240	1440	2645	4195	6710	10570	16765	24395	37700	48050	59510	86125	145080	208840	340055
260	1555	2855	4530	7245	11415	18095	26338	40705	51875	64250	92980	156630	225465	367130
280	1670	3065	4865	7775	12255	19430	28280	43705	55705	68990	99840	168185	242100	394220
300	1785	3275	5200	8310	13100	20770	30225	46710	59535	73730	106705	179750	258750	
350	2075	3800	6035	9650	15210	24115	35095	54240	69130	85615	123900	208715	300445	
400	2365	4330	6875	10995	17325	27475	39985	61795	78755	97535	141155	237780	342285	
450	2655	4865	7720	12345	19455	30845	44890	69380	88425	109510	158485	266975		
500	2945	5400	8570	13705	21590	34235	49825	77005	98145	121550	175905	296320		
600	3535	6475	10280	16440	25910	41085	59790	92400	117765	145850	211075	355565		
700	4130	7575	12020	19225	30290	48030	69900	108030	137680	170515	246770			
800	4740	8685	13790	22050	34750	55100	80190	123925	157945	195610	283090			
900	5360	9825	15595	24940	39295	62310	90685	140150	178620	221215	320145			
1000	5995	10990	17440	27890	43950	69690	101425	156745	199775	247410	358055			
1100	6645	12180	19335	30920	48725	77260	112440	173770	221475	274285	396950			
1200	7314	13410	21285	34040	53635	85050	123780	191295	243805	301945	436975			
1300	8005	14675	23300	37260	58710	93095	135485	209385	266860	330500				
1400	8720	15990	25385	40595	63965	101425	147610	228125	290745	360080				
1500	9470	17355	27555	44060	69430	110090	160220	247610	315585					
1600	10245	18785	29815	47680	75135	119135	173385	267960	341515					
1700	11060	20270	32190	51480	81115	128625	187195	289300	368715					
1800	11920	21855	34695	55480	87425	138625	201750	311795	397385					
1900	12835	23525	37345	59725	94110	149225	217175							
2000	13805	25310	40175	64245	101240	160530	233625							
2100	14850	27225	43215	69110	108900	172675	251305							
2200	15980	29300	46510	74375	117195	185831	270450							
2300	17220	31565	50110	80130	126265	200215	291380							
2400	18585	34075	54090	86495	136295	216120	314530							
2500	20120	36885	58550	93625	147535	233940	340465							
2700	23890	43800	69525	111180	175190	277795								
2900	29345	53800	85400	136560	215195	341225								
3100	39765	72905	115735	185070	291630	462425								

(*) It is recommended, if possible, selecting the orifice by applying the calculation formulas. These tables can be useful when a quick estimation of the orifice is required. Atmospheric pressure will be considered

Liquids discharge flow / Capacity chart - liquids

$$A = \frac{W}{38 \cdot K \cdot K3 \cdot Kv} \sqrt{\frac{E}{(P - Pb)}}$$

Flow:			GPM	The results shown correspond to calculations for water. For different relative densities of water to 1, multiply by Kg. Minimum overpressure 2.90 psig											
Overpressure:			10%												
Discharge coefficient derated:			0.720												
P1	D	E	F	G	H	J	K	L	M	N	P	Q	R	T	
psig	0.12	0.22	0.35	0.56	0.89	1.41	2.05	3.16	4.03	4.99	7.22	12.17	17.52	28.52	
5	75	135	215	345	545	865	1260	1945	2475	3070	4440	7480	10765	17530	
10	95	175	275	445	695	1105	1610	2485	3170	3925	5680	9570	13775	22430	
15	110	205	325	520	820	1305	1895	2930	3735	4625	6695	11280	16235	26440	
20	125	230	370	590	930	1475	2145	3315	4225	5235	7575	12760	18370	29915	
25	140	255	405	650	1025	1630	2370	3660	4660	5780	8365	14090	20280	33025	
30	150	280	445	710	1120	1770	2580	3985	5080	6290	9105	15340	22080	35955	
35	165	300	480	765	1205	1915	2785	4305	5485	6795	9835	16570	23850	38835	
40	175	325	510	820	1290	2045	2980	4605	5865	7265	10515	17710	25495	41515	
45	185	340	545	870	1370	2170	3160	4880	6220	7705	11150	18785	27045	44035	
50	195	360	575	915	1445	2290	3330	5145	6560	8125	11755	19800	28505	46415	
60	215	395	625	1005	1580	2505	3650	5635	7185	8900	12875	21690	31225	50845	
70	235	425	680	1085	1705	2705	3940	6090	7760	9610	13910	23430	33730	54920	
80	250	455	725	1160	1825	2895	4210	6510	8295	10275	14870	25050	36055	58710	
90	265	485	770	1230	1935	3070	4465	6905	8800	10900	15770	26570	38245	62275	
100	280	510	810	1295	2040	3235	4710	7280	9275	11485	16625	28005	40315	65640	
120	305	560	885	1420	2235	3545	5160	7970	10160	12585	18210	30680	44160	71905	
140	330	605	960	1530	2415	3830	5570	8610	10975	13590	19670	33135	47700	77670	
160	350	645	1025	1640	2580	4095	5955	9205	11735	14530	21030	35425	50990	83030	
180	375	685	1085	1735	2740	4340	6320	9765	12445	15410	22305	37570	54085	88070	
200	395	720	1145	1830	2885	4575	6660	10290	13120	16245	23510	39605	57010	92830	
220	415	755	1200	1920	3025	4800	6985	10795	13760	17040	24660	41540	59795	97365	
240	430	790	1255	2005	3160	5015	7295	11275	14370	17795	25755	43385	62450	101690	
260	450	825	1305	2090	3290	5215	7595	11735	14955	18525	26805	45155	65000		
280	465	855	1355	2165	3415	5415	7880	12180	15525	19220	27820	46860	67455		
300	480	885	1405	2245	3535	5605	8155	12605	16065	19900	28795	48505	69825		
350	520	955	1515	2425	3820	6055	8810	13615	17355	21490	31100	52390	75420		
400	555	1020	1620	2590	4080	6470	9420	14555	18550	22975	33250	56010			
450	590	1080	1720	2745	4330	6865	9990	15440	19675	24370	35265	59405			
500	620	1140	1810	2895	4565	7235	10530	16275	20740	25685	37175	62620			
600	680	1250	1985	3170	5000	7925	11535	17825	22720	28140	40720	68600			
700	735	1350	2145	3425	5400	8560	12460	19255	24540	30395	43985				
800	787	1445	2290	3665	5770	9150	13320	20585	26235	32490	47020				
900	835	1530	2430	3885	6120	9705	14125	21835	27825	34460	49875				
1000	880	1615	2560	4095	6455	10230	14890	23015	29330	36325	52570				
1100	923	1690	2685	4295	6770	10730	15620	24135	30765	38100	55135				
1200	964	1765	2805	4485	7070	11210	16315	25210	32130	39795	57590				
1300	1003	1840	2920	4670	7360	11665	16980	26240	33445	41420					
1400	1041	1910	3030	4845	7635	12105	17620	27230	34705	42980					
1500	1078	1975	3135	5015	7905	12530	18240	28185	35925	44490					
1600	1113	2040	3240	5180	8160	12945	18835	29110	37100						
1700	1147	2105	3340	5340	8415	13340	19415	30005	38245						
1800	1181	2164	3436	5494	8658	13728	19979	30877	39353						
1900	1213	2224	3530	5645	8895	14104	20526								
2000	1244	2281	3622	5791	9126	14471	21060								
2100	1275	2338	3711	5934	9351	14828	21580								
2200	1305	2393	3798	6074	9571	15177	22088								
2300	1335	2447	3884	6211	9786	15518	22584								
2400	1363	2499	3967	6344	9997	15852	23070								
2500	1391	2551	4049	6475	10203	16179	23545								
2700	1446	2651	4208	6729	10603	16813									
2900	1499	2747	4361	6974	10989	17425									
3100	1549	2840	4509	7210	11362	18016									
3400	1623	2975	4722	7551											
3700	1693	3103	4926	7877											
4000	1760	3226	5122	8190											
4300	1825	3345	5310												
4600	1887	3460	5492												
4900	1948	3571	5669												

Correction coeff.	
Spec. Grvty.	
D	lbs
0.20	4.94
0.30	4.02
0.40	3.48
0.50	3.12
0.60	2.91
0.70	2.63
0.80	2.46
0.84	2.41
0.88	2.35
0.92	2.30
0.96	2.25
1.00	2.20
1.04	2.16
1.08	2.12
1.12	2.08
1.16	2.05
1.20	2.01
1.30	1.93

(*)It is recommended, if possible, selecting the orifice by applying the calculation formulas. These tables can be useful when a quick estimation of the orifice is required. Atmospheric pressure will be considered

■ Technical information / API selection chart

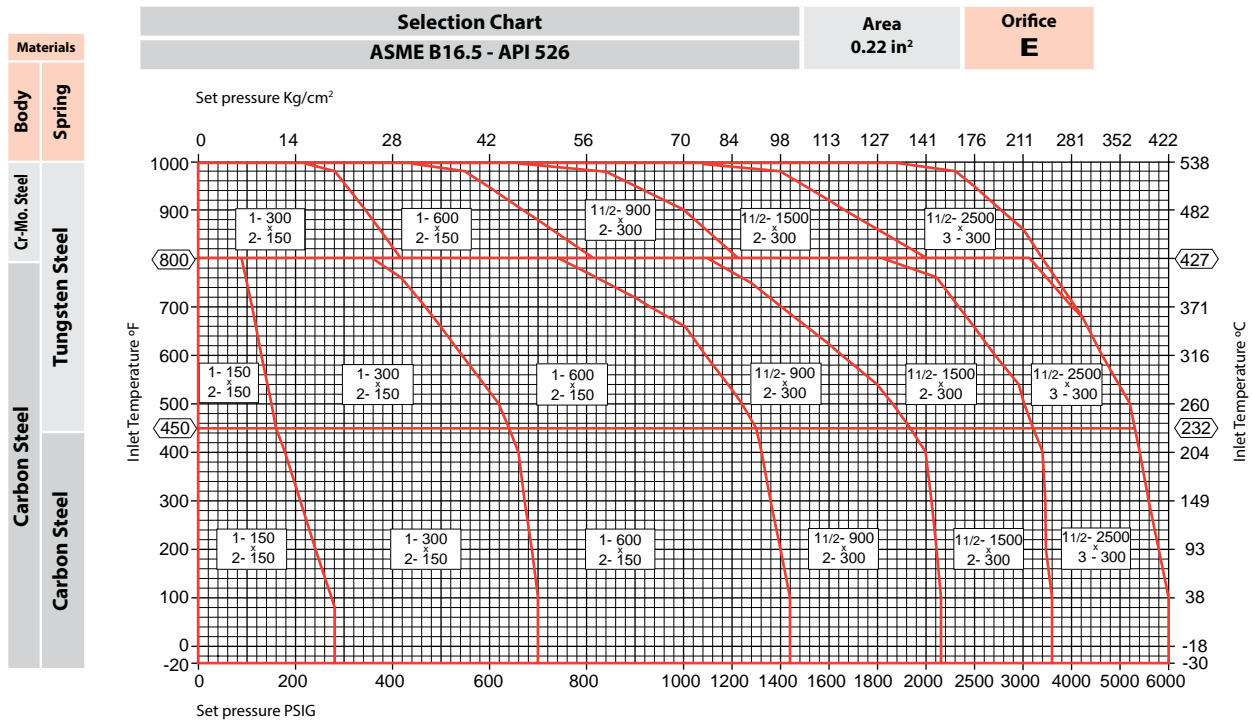
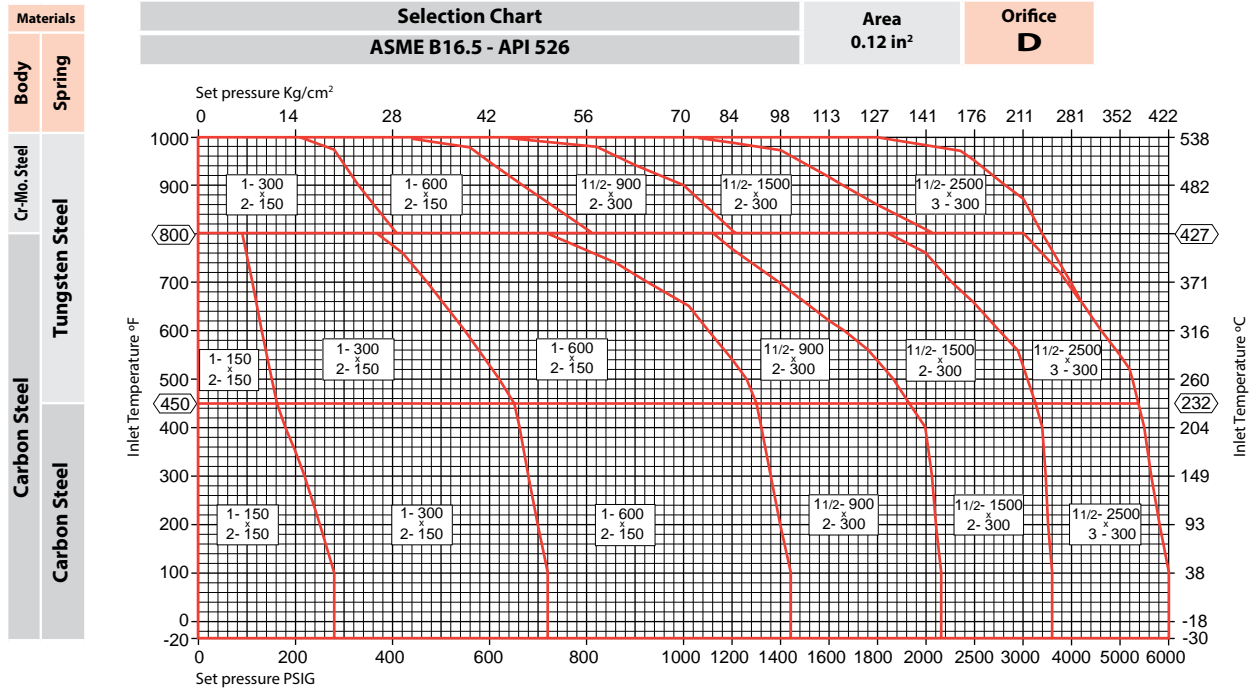

■ Technical information / API selection chart

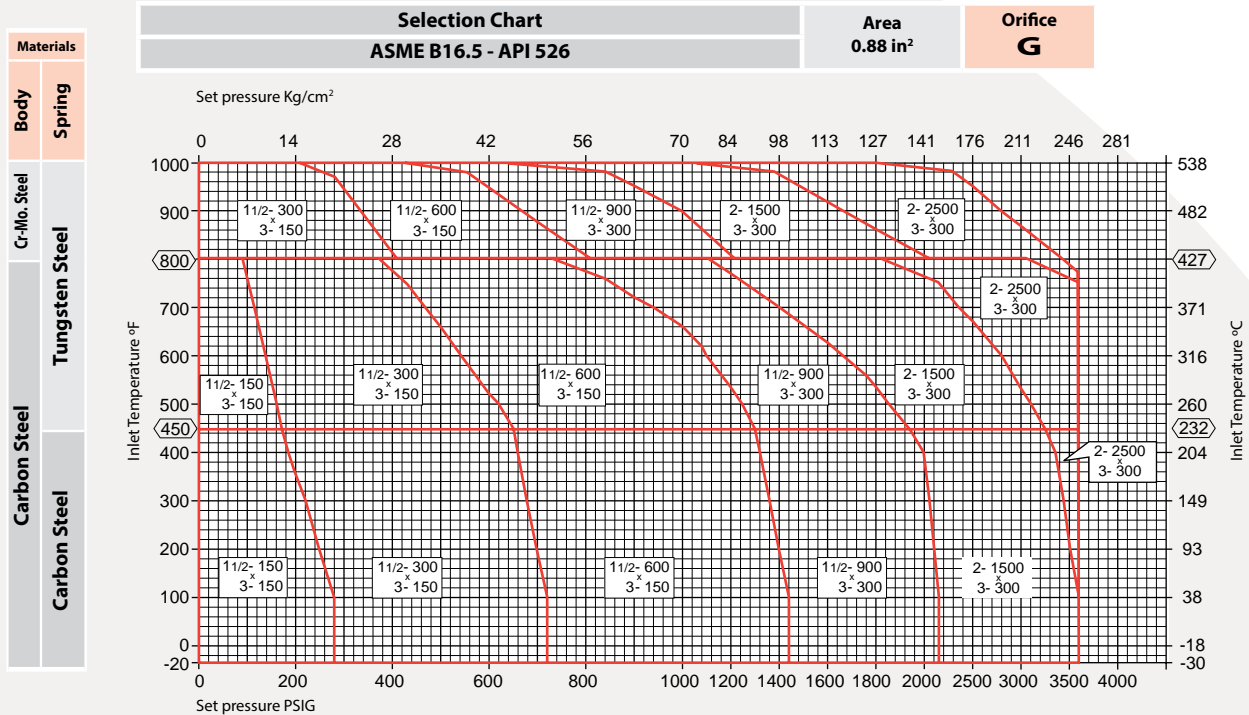
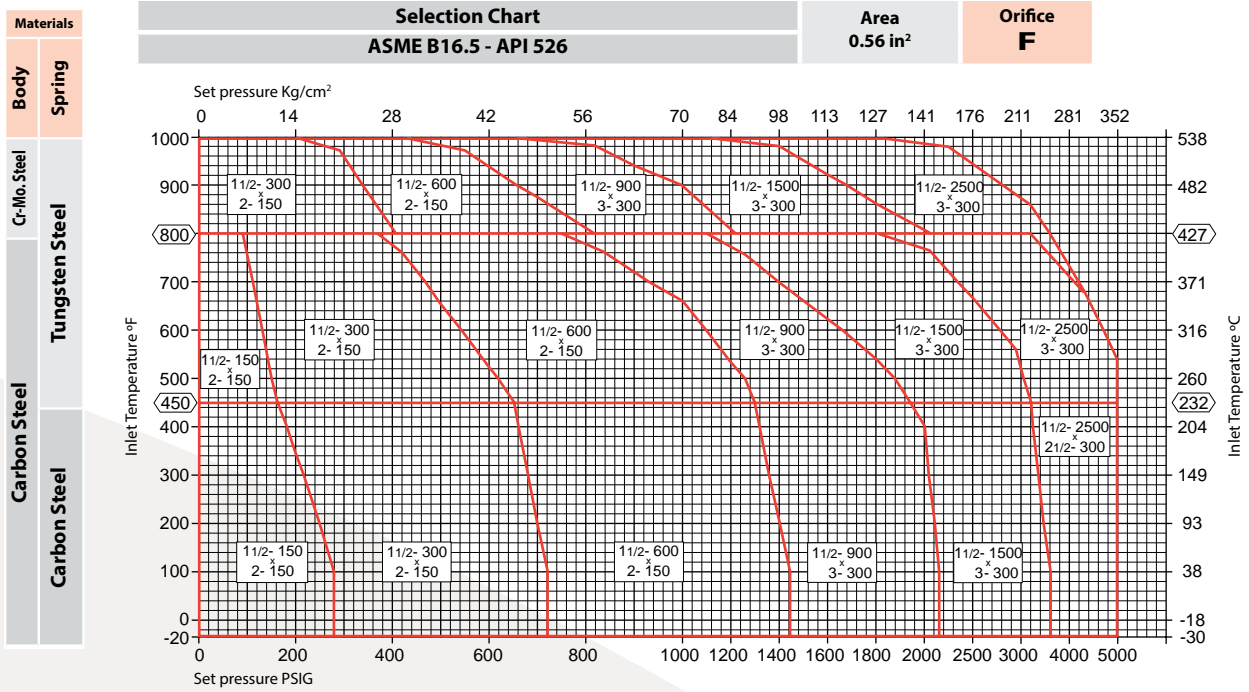

■ Technical information / API selection chart

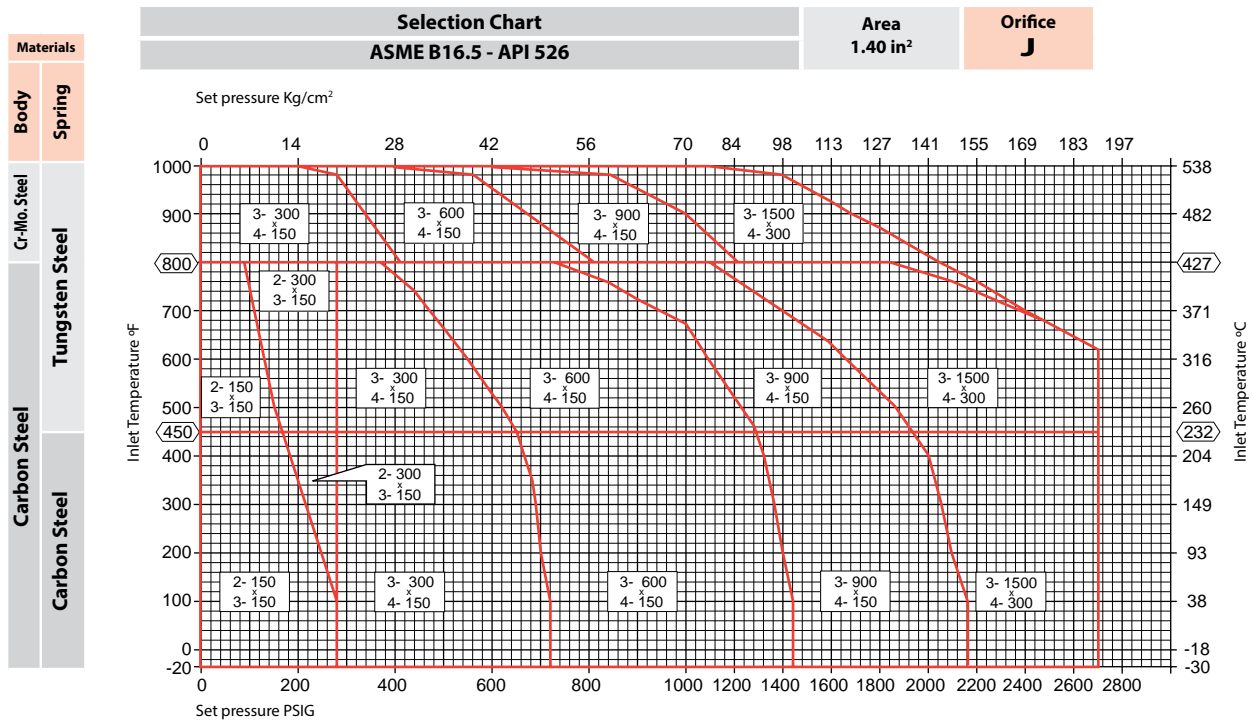
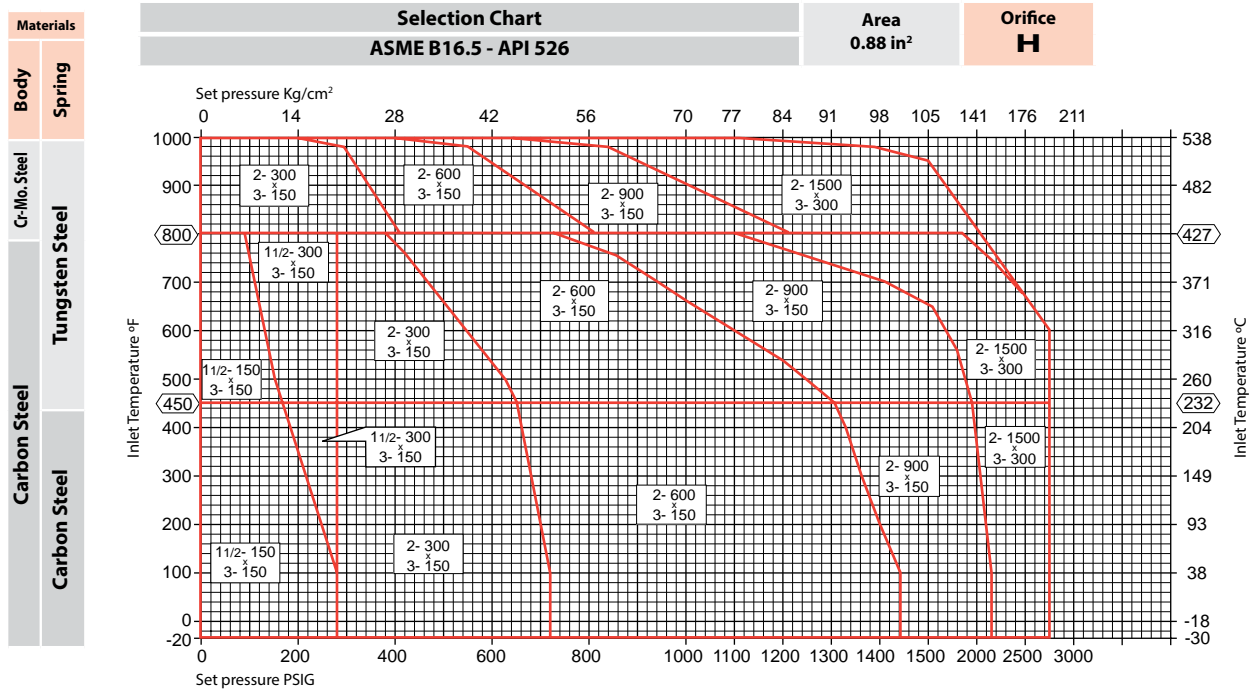

■ Technical information / API selection chart

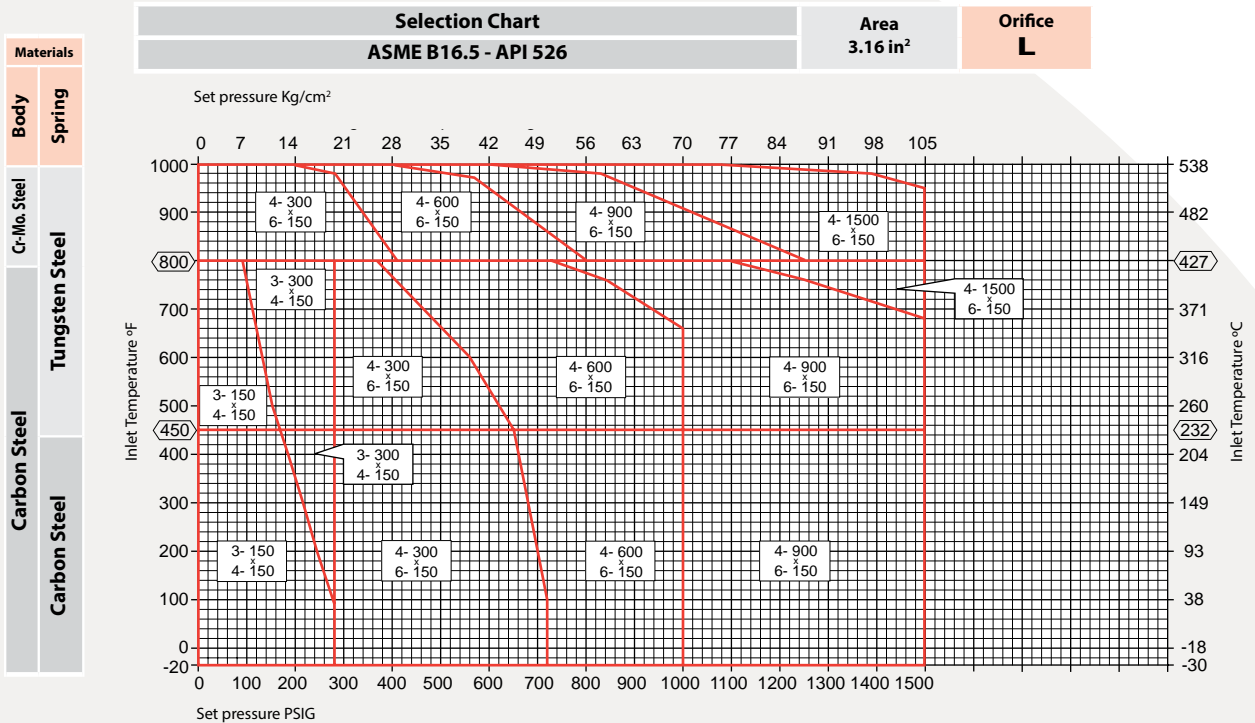
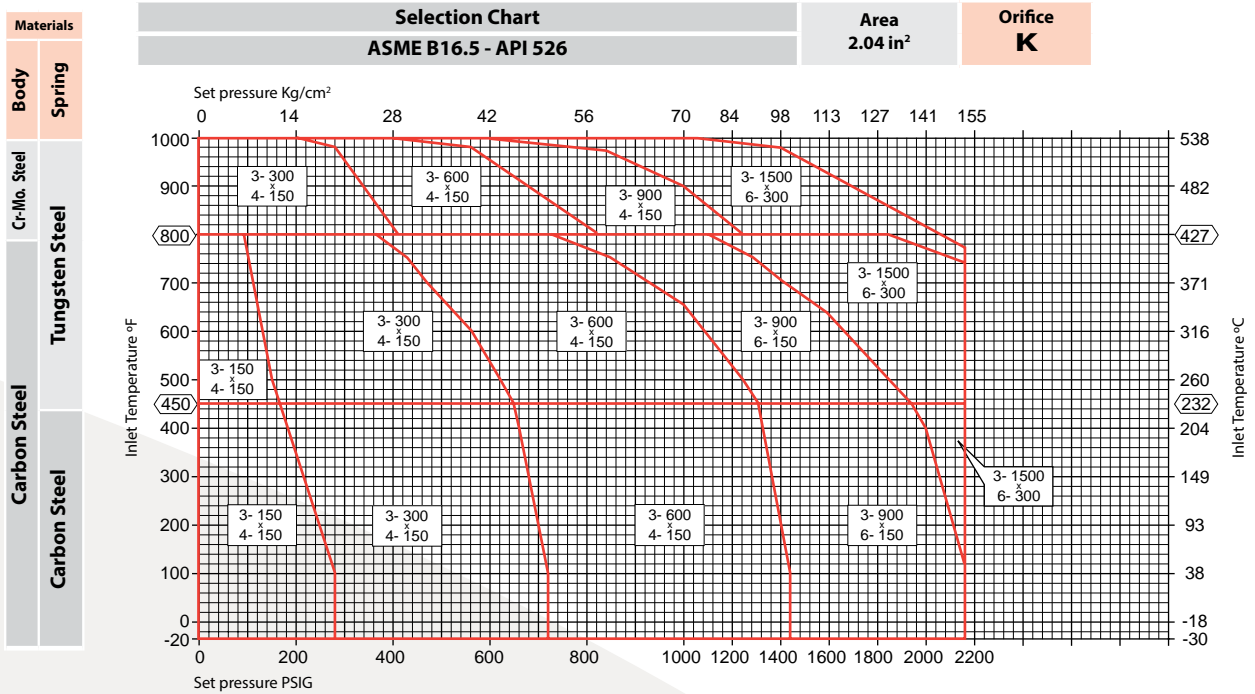

■ Technical information / API selection chart

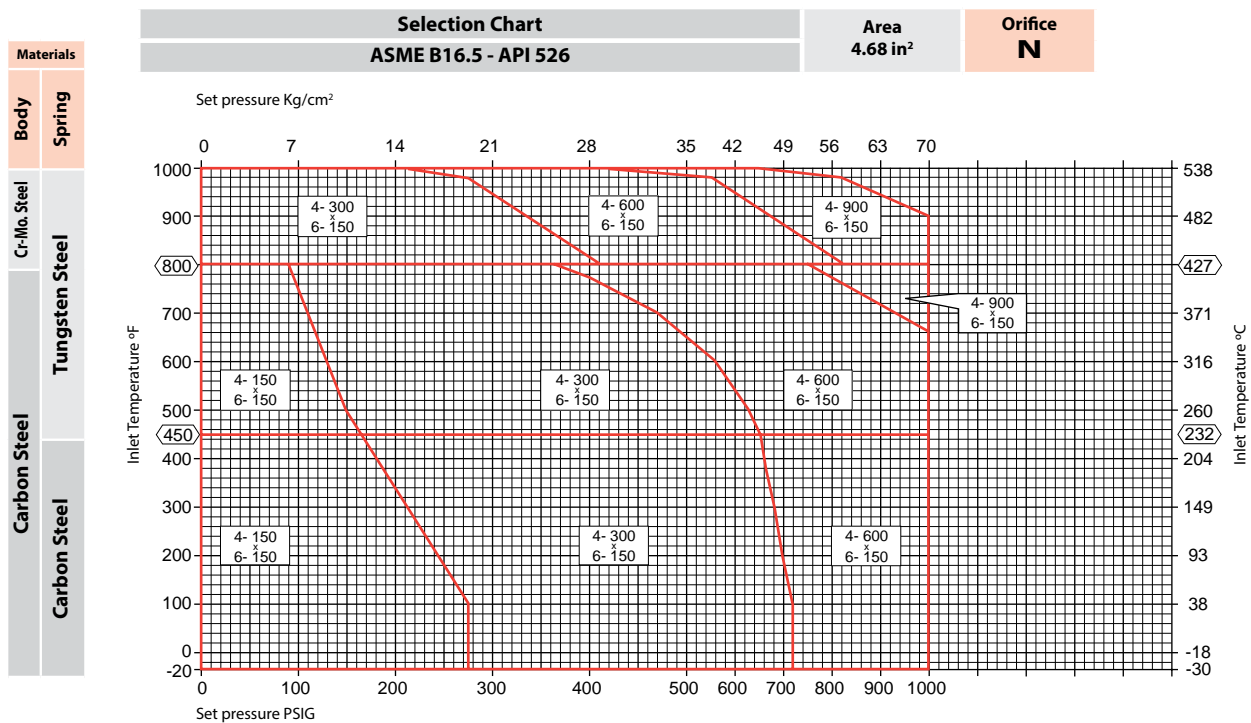
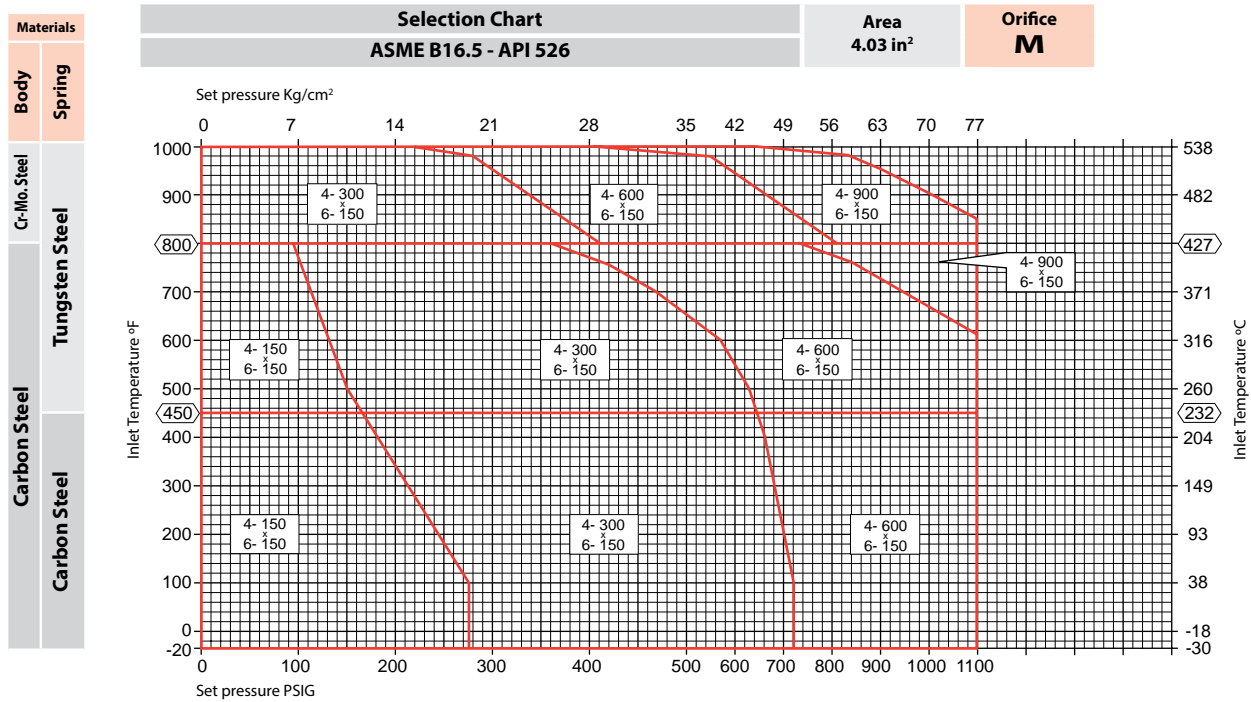

■ Technical information / API selection chart

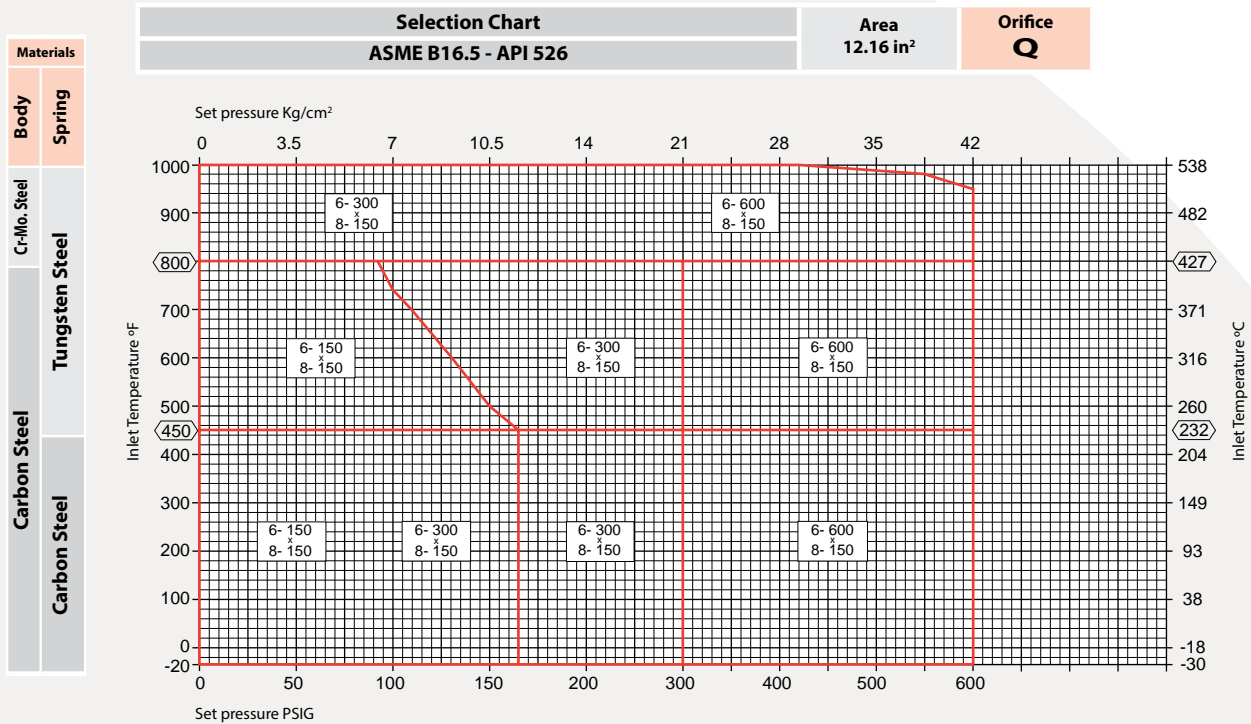
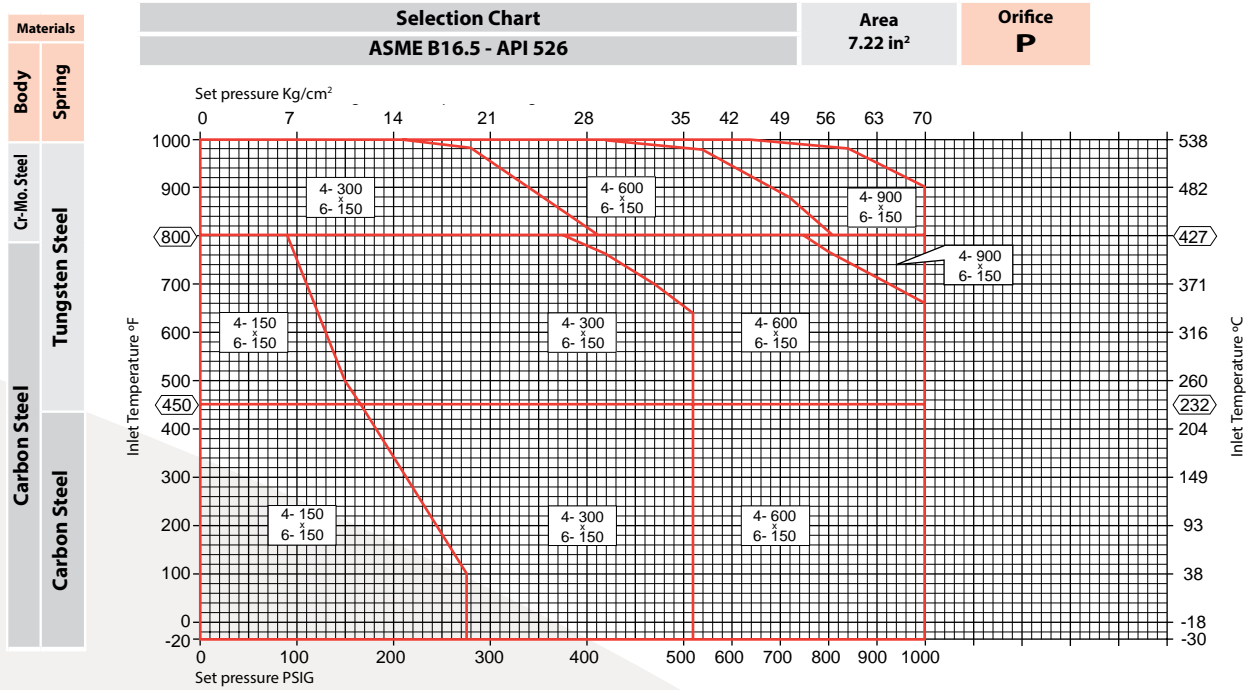

■ Technical information / API selection chart

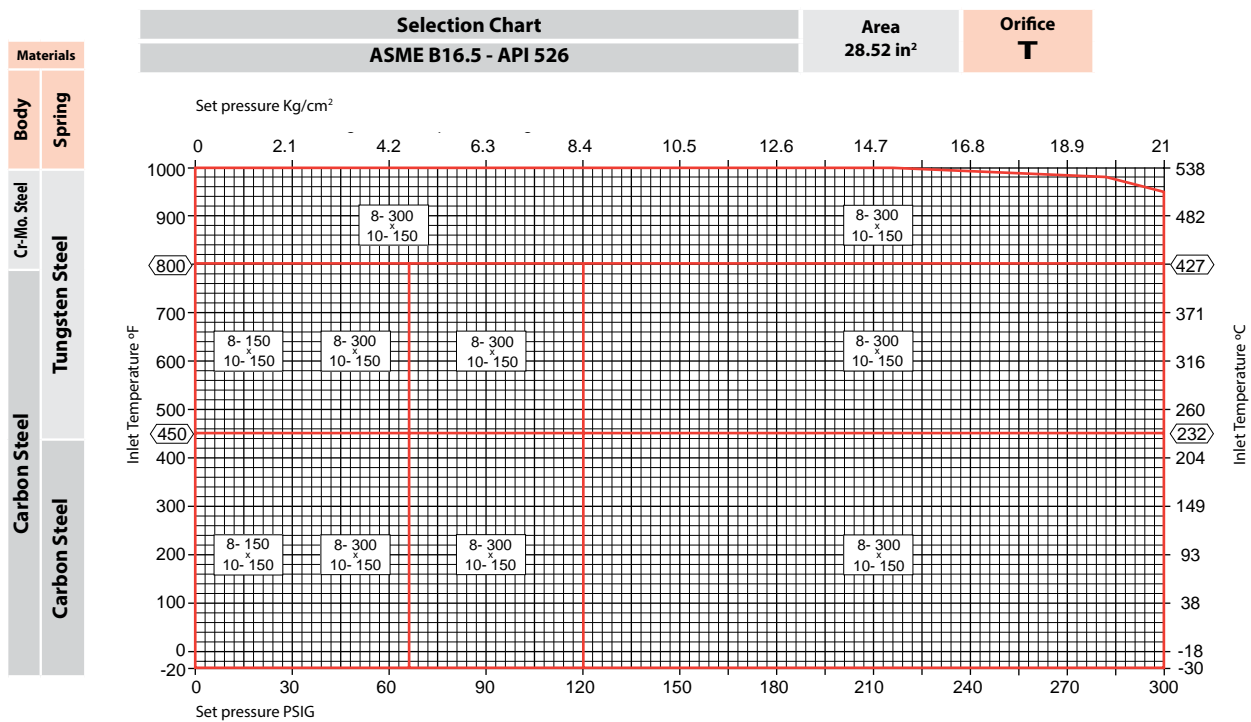
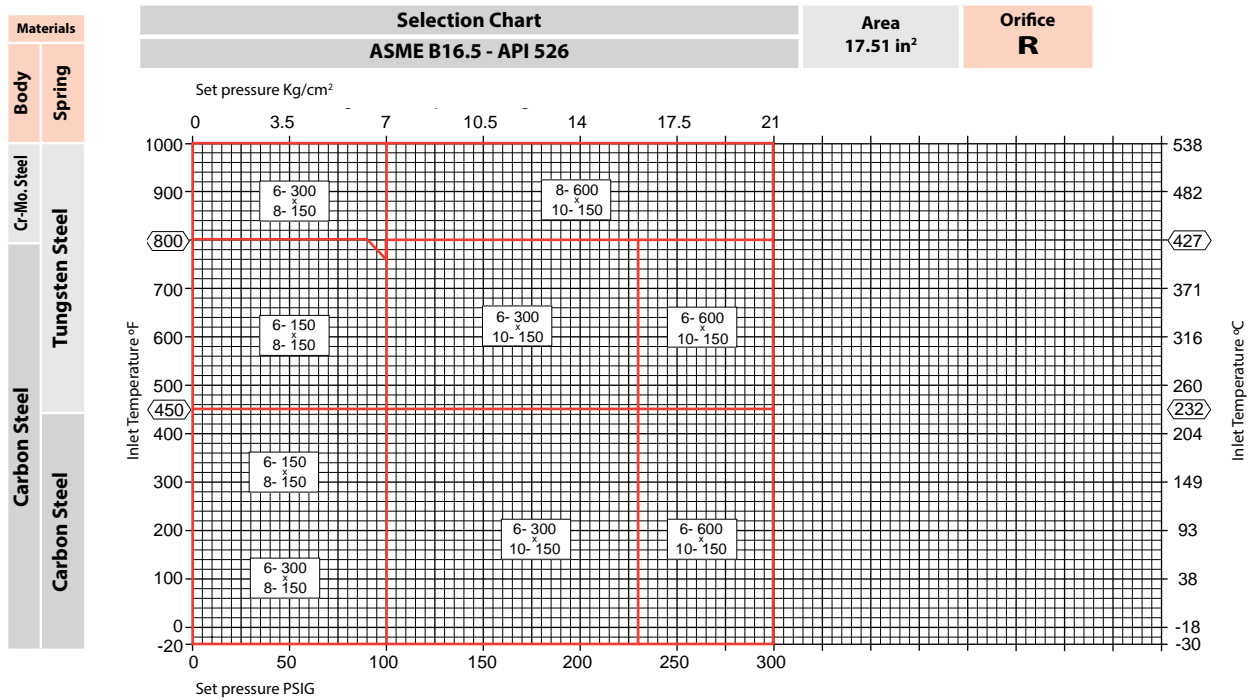

■ Technical information / Reaction forces during discharge

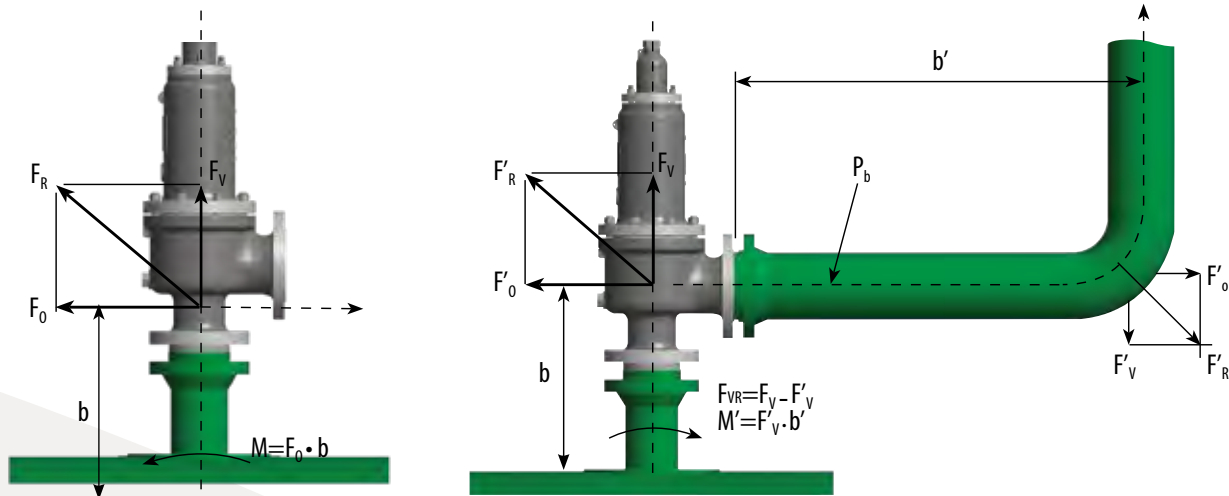

$$F_0 = \frac{W}{27.8} \sqrt{\frac{k}{k+1} \cdot \frac{T_1}{M}}$$

For practical use:

$$F_0 = 0.1 \cdot W \sqrt{\frac{P_1}{\zeta_1}}$$

$$F_V = 10 \cdot P_1 \cdot A_1 + \frac{W \cdot v_1}{3600}$$

$$F_0^1 = F_0 + 10 \cdot P_b \cdot A_2$$

$$F_V^1 \cong F_0$$

- A_1 (in²) = Inlet pipe area
- A_2 (in²) = Outlet pipe area
- M = Molecular weight
- P_1 (psig) = Inlet pressure during valve discharge
- P_b (psig) = Back pressure
- T_1 (°K) = Inlet temperature
- v_1 (ft/s) = Inlet average fluid velocity
- W (lb/h) = Discharge flow
- k (cp/c_v) = Specific heat ratio
- ζ_1 (lbm/ft³) = Specific mass of inlet fluid
- F (lbf) = Reaction forces

■ Technical information / Noise discharge calculation

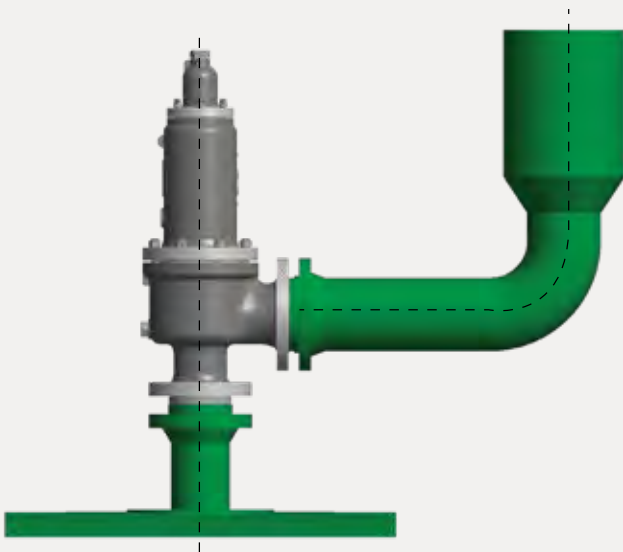

$$L_{pa} \text{ a } 1 \text{ m} = 86 + 10 \cdot \log_{10} \frac{W \cdot K \cdot T}{M}$$

For distances higher than 1 m, use the following formulas:

$$L_{PL} = L_{P_1} - 20 \cdot \log_{10} L + 3$$

When the discharge is fairly near to the soil.

$$L_{PL} = L_{P_1} - 20 \log_{10} L$$

When the discharge is high over the soil.

- LP = Noise level (db)
- W = Discharge flow (lb/h)
- k = Specific heat ratio (cp/cv)
- T = Discharge temperature (°K)
- M = Molecular weight
- L = Distance between measuring and discharge point. (ft)

■ Definitions (ASME PTC 25)

Actual discharge area: The measured minimum net area that determines the flow through a valve.

Coefficient of discharge: The ratio of the measured relieving capacity to the theoretical relieving capacity.

Conventional direct spring-loaded PRV: A direct spring-loaded pressure relief valve whose operational characteristics are directly affected by changes in the back pressure.

Back pressure: The static pressure existing at the outlet of a pressure relief device due to pressure in the discharge system.

Balanced direct spring-loaded PRV: A direct spring-loaded pressure relief valve that incorporates means of minimizing the effect of back pressure on the operational characteristics (opening pressure, closing pressure, and relieving capacity) of the valve.

Blowdown: The difference between actual relieving pressure of a pressure relief valve, and actual reseating pressure, expressed as a percentage of set pressure (or in pressure units).

Blowdown pressure: The value of decreasing inlet static pressure at which no further discharge is detected at the outlet of a pressure relief valve, after the valve has been subjected to a pressure equal to or above the relieving pressure.

Bore area: The minimum cross-sectional flow area of a nozzle.

Bore diameter: The minimum diameter of a nozzle.

Built-up back pressure: Pressure existing at the outlet of a pressure relief device caused by the flow through that particular device into a discharge system.

Cold differential test pressure: The inlet static pressure at which a pressure relief valve is adjusted to open on the test stand. This test pressure includes corrections for service conditions of superimposed back pressure and/or temperature.

Constant back pressure: A superimposed back pressure that is constant over time.

Developed lift: The actual travel of the disk from the closed position to the open position reached when the valve is at flow-rating pressure.

Effective discharge area: A nominal or computed area of flow through a pressure relief valve, differing from the actual discharge area, for use in recognized flow formulas to determine the capacity of a pressure relief valve.

Effective seat area: A computed area for use in calculating the set pressure of a given pressure relief valve when tested using an auxiliary lift-assist device.

Flow path: The three-dimensional and geometric characteristics of a device that affects the measured relieving capacity. It is defined from the cross section of the inlet to the cross section of the outlet.

Inlet size: The nominal pipe size of the inlet of a pressure relief valve.

Leak test pressure: The specified inlet static pressure at which a quantitative seat leakage test is performed in accordance with a standard procedure.

Lift: The actual travel of the disk away from the closed position when a valve is relieving.

Maximum allowable pressure: The maximum pressure for which the equipment is designed as specified by the manufacturer.

Outlet size: The nominal pipe size of the outlet of a pressure relief valve, unless otherwise designated.

■ Definitions (ASME PTC 25) *continued*

Overpressure: A pressure increase over the set pressure of a pressure relief valve, usually expressed as a percentage of set pressure.

Popping pressure: The value of increasing the inlet static pressure, so the disk opens faster.

Pressure: The pressure unit used in this standard is psi or bar. It is quoted as gauge (relative to atmospheric pressure) or absolute as appropriate.

Pressure Relief Valve (PRV): A pressure relief device designed to actuate on inlet static pressure and reclose after normal conditions have been restored.

Re-seating pressure: The value of decreasing inlet static pressure at which the valve disk re-establishes contact with the seat or at which lift becomes zero.

Relieving pressure: Set pressure plus overpressure.

Safety valve: A pressure relief valve characterized by rapid opening and normally used to relieve compressible fluids.

Set pressure: The value of the inlet static pressure at which a pressure relief device displays one of the operational characteristics as defined under opening pressure, popping pressure, start-to-leak pressure, burst pressure, or breaking pressure. (The applicable operating characteristic for a specific device design is specified by the device manufacturer).

Safety relief valve: A pressure relief valve characterized by rapid opening or by gradual opening that is generally proportional to the increase in pressure. It can be used for compressible or incompressible fluids.

Superimposed back pressure: The static pressure existing at the outlet of a pressure relief device at the time the device is required to operate. It is the result of pressure in the discharge system from other sources.

■ Safety valve main components:

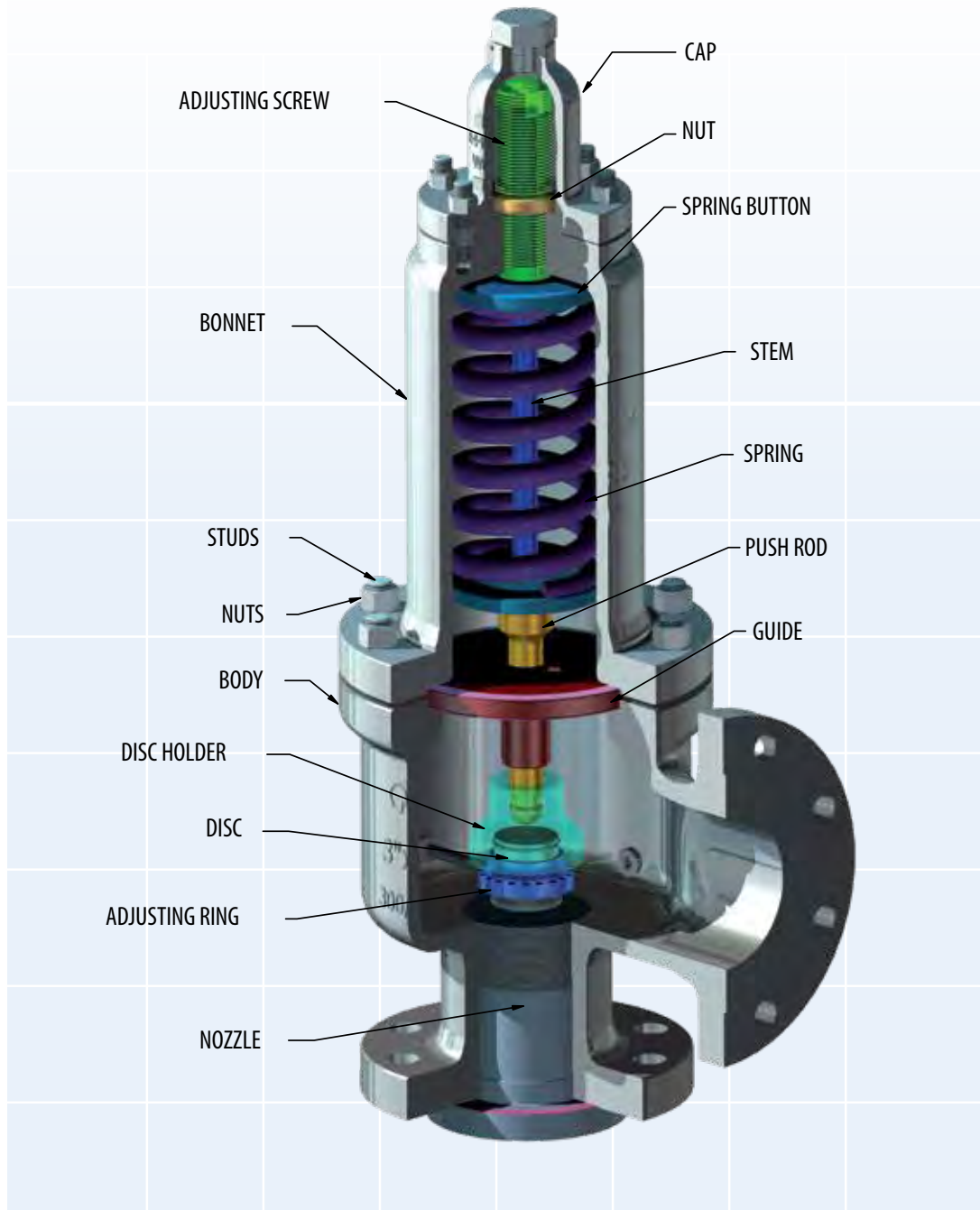



Compositor Vivaldi, 2 – 8
Pol. Ind Can Jardí
08191 RUBI (Barcelona – Spain)
Tel.: +34 936 995 200
safety@valvulasnacional.com
www.valvulasnacional.com

7455 East 46th Street
Tulsa, Oklahoma 74145
Tel.: 918 622 5950
Fax: 918 665 3904
sales@bsbsystems.com
www.bsbsystems.com

Products, specifications and all data in this literature are subject to change without notice. Questions regarding product selection and specifications for specific applications should be directed to BS&B. All sales are subject to the BS&B companies' standard terms and conditions of sale. Nothing herein should be construed as a warranty of merchantability or fitness for a particular purpose.

BSBSystems.com | BSB.ie

© 2018, BS&B Innovations, Limited. Revised March 2018.