

SMARTFLOW[®] Mechanical Flowmeters

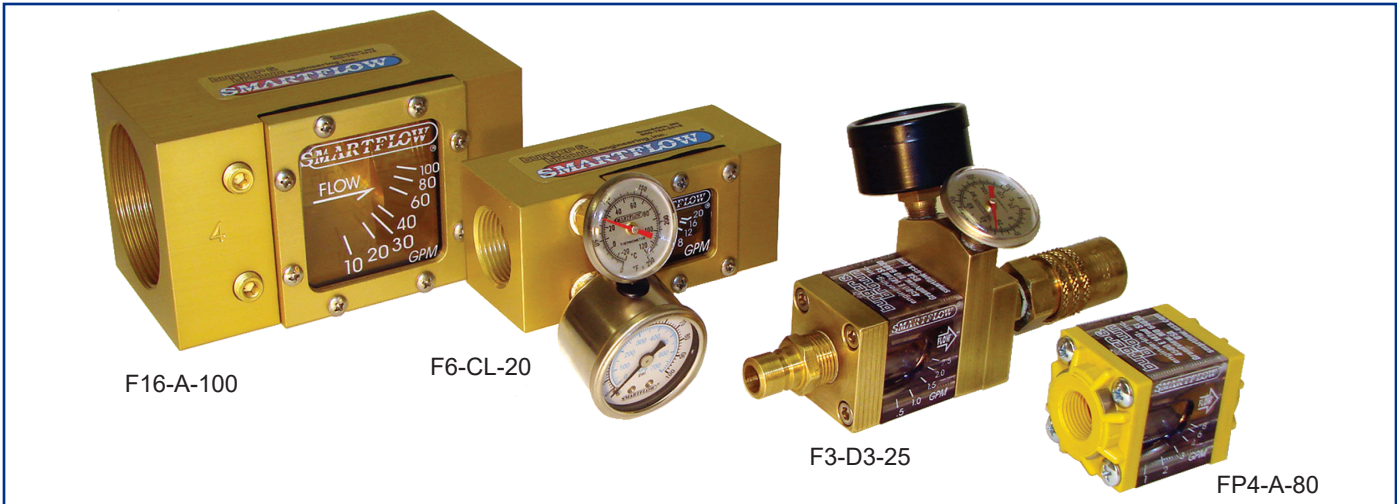

General Description

Smartflow mechanical flowmeters are durable, vane-operated devices that provide visual indication of flow rate in many different styles and sizes. Rugged wetted parts are compatible with many process liquids.

Optional temperature and pressure gauges add functionality and flexibility to Smartflow flowmeters. Brass quick-connect fittings are available on the smaller flowmeters to create an excellent, portable tool for determining flow and locating clogged lines.

Features and Benefits

- ◆ **Compact size** works well in restricted-space locations.
- ◆ **Rugged construction** gives years of dependable service.
- ◆ **Variety of inlet sizes** provides exactly the right connection.
- ◆ **210°F (99°C) Temperature Rating** allows installation into a wide range of applications.
- ◆ **Optional Temperature and Pressure Gauges** give instant access to pressure and temperature information in addition to flow in one unit.
- ◆ **No Mounting Restrictions** ease installation in any position without extra brackets or hardware.

Galvanic corrosion may occur in anodized aluminum components when installed in electrical connection with more noble metals such as copper. Use appropriate installation practices.

For best performance, mechanical flowmeters should be installed in the vertical position with the flow moving upwards.

Turbulent Flow

Injection molders know that a certain rate of flow is needed to achieve turbulent flow in cooling lines. This concept applies to most cooling applications using a water-based coolant mixture. Charts below are for reference only. Turbulent Flow Rate is approximate based on Reynolds Number of 4000.

Passage Diameter	Nominal Pipe Size	Minimum Flow in GPM by Temperature		
		40°F	120°F	200°F
.44"	1/4"	0.88	0.31	0.18
.59"	3/8"	1.16	0.42	0.24
.72"	1/2"	1.41	0.51	0.29

Passage Diameter	Nominal Pipe Size	Minimum Flow in LPM by Temperature		
		4°C	49°C	93°C
11mm	1/4"	3.3	1.2	0.7
15mm	3/8"	4.4	1.6	0.9
18mm	1/2"	5.3	1.9	1.1

Use our on-line turbulent flow calculator to input additional sizes and cooling variables:

[www.Smartflow-usa.com/
Turbulent-Flow-Rate-Calculator](http://www.Smartflow-usa.com/Turbulent-Flow-Rate-Calculator)

Model Number

F3 - D3 - 25

Inlet Size	
Brass Ends	
1/4"NPT	F2
1/4"BSPP	F2B
3/8"NPT	F3
3/8"BSPP	F3B
1/2"NPT	F4
1/2"BSPP	F4B
3/4"NPT	F6
3/4"BSPP	F6B

Nylon Ends	
1/4"NPT	FP2
1/4"BSPP	FP2B
3/8"NPT	FP3
3/8"BSPP	FP3B
1/2"NPT	FP4
1/2"BSPP	FP4B

Flow Range

15	0.2 - 1.5 gpm (gallons per minute)
25	0.5 - 2.5 gpm
80	1.0 - 8.0 gpm
100	2 - 10 lpm (liters per minute)
200	5 - 20 lpm
300	4 - 30 lpm

Accessories

- A** Flowmeter only
- B** Thermometer
- C1** Thermometer and 30 psi Pressure Gauge
- C2** Thermometer and 60 psi Pressure Gauge
- C3** Thermometer and 100 psi Pressure Gauge
- CL** Thermometer and Liquid-Filled Pressure Gauge (100 psi)
- D1** *Thermometer, 30 psi Pressure Gauge, Quick Change Socket and Plug
- D2** *Thermometer, 60 psi Pressure Gauge, Quick Change Socket and Plug
- D1** *Thermometer, 100 psi Pressure Gauge, Quick Change Socket and Plug
- DL** *Thermometer, Liquid-Filled Pressure Gauge (100 psi), Quick Change Socket and Plug
- E** *Thermometer, Quick Change Socket and Plug
- F1** 30 psi Pressure Gauge
- F2** 60 psi Pressure Gauge
- F3** 100 psi Pressure Gauge
- FL** Liquid-Filled Pressure Gauge (100 psi)

*Not available with 3/4" inlet or BSPP threads

Wetted Parts and Materials

End Caps.....	Brass or Glass-Filled Nylon
Body.....	Polysulfone
Vane.....	Glass-Filled Nylon
Spring.....	Stainless Steel
O-Rings.....	EPDM
Cap Screws.....	Stainless Steel
Optional Gauge Block.....	Brass
Optional Quick-Connect Fittings.....	Brass

Specifications

Flow Accuracy.....	±10% full scale
Operating Temperature max.....	210°F (99°C)
Operating Pressure max.....	100 psi (6.9 bar)
Optional Thermometer.....	0 to 250°F (-20° to 120°C)
	±2% accuracy (full scale)
Optional Pressure Gauge...±3% accuracy	(full scale)

For Custom Manifold Assemblies and 3D CAD files of Standard Components Visit

www.ManifoldBuilder.com

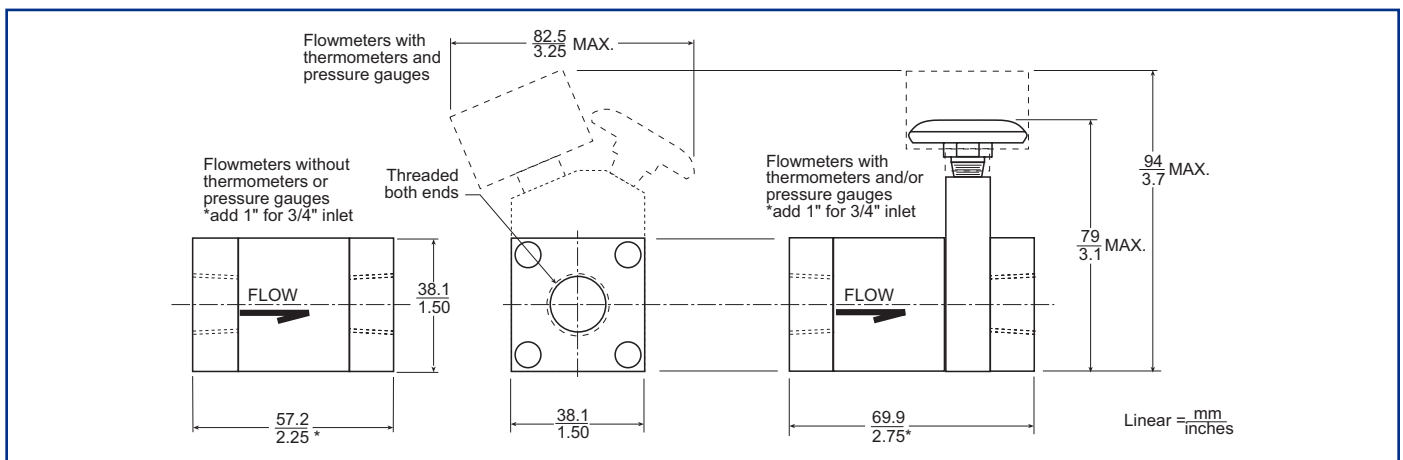

Model Number

F6 - B - 20

Inlet Size

3/4"NPT	F6
3/4"BSPP	F6B
1"NPT	F8
1"BSPP	F8B

Flow Range

20	2 - 20 gpm (gallons per minute)
75	7 - 75 lpm (liters per minute)

Accessories

- A** Flowmeter only
- B** Thermometer
- C1** Thermometer and 30 psi Pressure Gauge
- C2** Thermometer and 60 psi Pressure Gauge
- C3** Thermometer and 100 psi Pressure Gauge
- CL** Thermometer and Liquid-Filled Pressure Gauge (100 psi)
- F1** 30 psi Pressure Gauge
- F2** 60 psi Pressure Gauge
- F3** 100 psi Pressure Gauge
- FL** Liquid-Filled Pressure Gauge (100 psi)

Wetted Parts and Materials

Body.....	Anodized Aluminum
Sight Glass	Polysulfone
Vane	Stainless Steel
Spring	Stainless Steel
Pin	Stainless Steel
Gasket	Neoprene

Specifications

Flow Accuracy	±10% full scale
Operating Temperature max.....	210°F (99°C)
Operating Pressure max.....	100 psi (6.9 bar)
Optional Thermometer.....	0 to 250°F (-20° to 120°C)
	±2% accuracy (full scale)
Optional Pressure Gauge	±3% accuracy (full scale)

Galvanic corrosion may occur in anodized aluminum components when installed in electrical connection with more noble metals such as copper. Use appropriate installation practices.

Dimension Chart		
Dim.	Body Size	
	3/4"	1"
L	105	111
	4.125	4.375

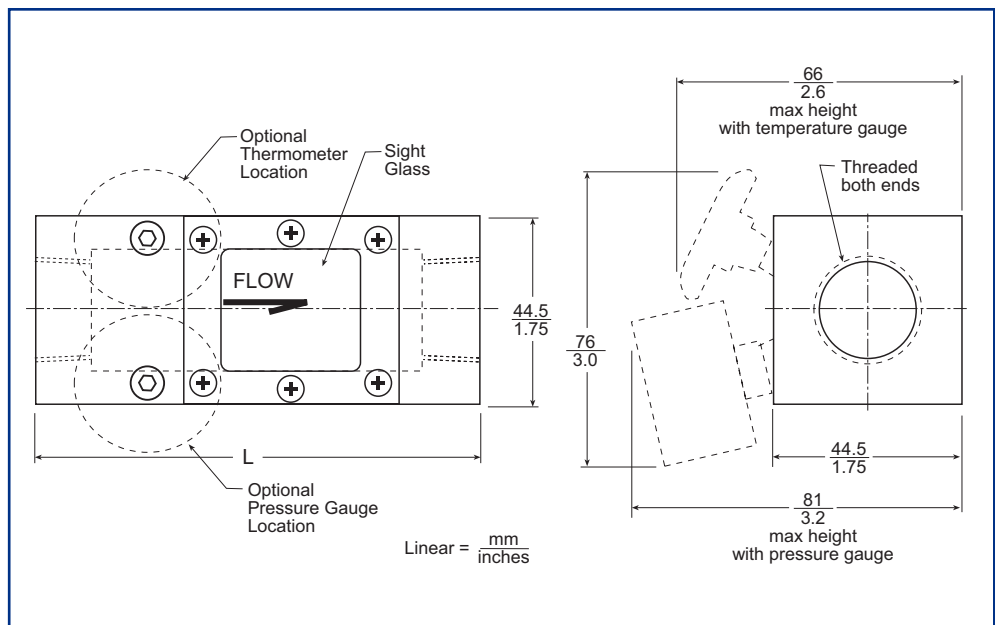

Model Number

F8 - B - 40

Inlet Size	
1"NPT	F8
1"BSPP	F8B
1-1/4"NPT	F10
1-1/2"NPT	F12
1-1/2"BSPP	F12B
2"NPT	F16
2"BSPP	F16B
3"NPT	F24

Flow Range	
2.5 - 40 gpm (excludes 3" inlet)	40
10 - 100 gpm (1-1/2" or 2" inlets only)	100
10 - 150 gpm (2" or 3" inlets only)	150G
19 - 150 lpm (excludes 3" inlet)	150
38 - 375 lpm (1-1/2" or 2" inlets only)	375

Accessories

Flowmeter only	A
Thermometer	B
Thermometer and 30 psi Pressure Gauge	C1
Thermometer and 60 psi Pressure Gauge	C2
Thermometer and 100 psi Pressure Gauge	C3
Thermometer and Liquid-Filled Pressure Gauge (100 psi)	CL
30 psi Pressure Gauge	F1
60 psi Pressure Gauge	F2
100 psi Pressure Gauge	F3
Liquid-Filled Pressure Gauge (100 psi)	FL

Wetted Parts and Materials

Body	Anodized Aluminum
Sight Glass	Polysulfone
Vane	Stainless Steel
Spring	Stainless Steel
Pin	Stainless Steel
Gasket	Neoprene

Specifications

Flow Accuracy	±10% full scale
Operating Temperature max.	210°F (99°C)
Operating Pressure max.	100 psi (6.9 bar)
Optional Thermometer	0 to 250°F (-20° to 120°C)
	±2% accuracy (full scale)
Optional Pressure Gauge	±3% accuracy (full scale)

1" and 1-1/4" Flowmeters 40 gpm & 150 lpm

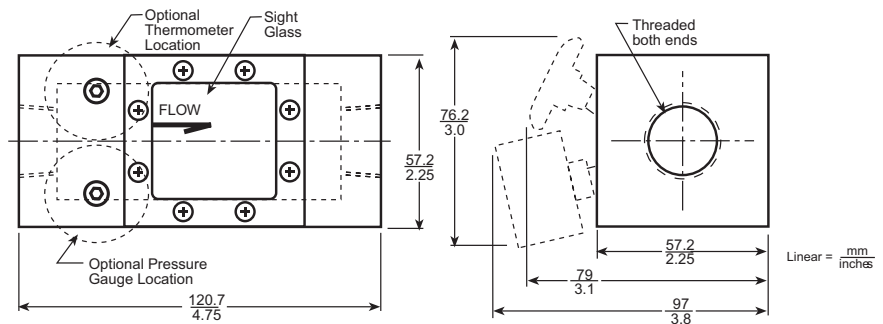

1-1/2", 2" & 3" Flowmeters 40, 100 & 150 gpm, 150 & 375 lpm

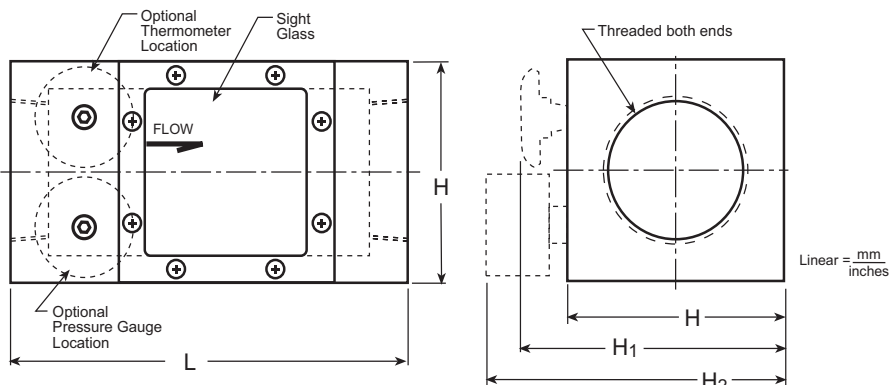

Dim.	Body Size	
	1-1/2" or 2"	3"
L	139.7	165.1
	5.5	6.5
H	76.2	101.6
	3.0	4.0
H ₁	99	124.5
	3.9	4.9
H ₂	114	139.7
	4.5	5.5

Galvanic corrosion may occur in anodized aluminum components when installed in electrical connection with more noble metals such as copper. Use appropriate installation practices.