

CANTY

PROCESS TECHNOLOGY

EXTREME TEMP™ FURNACE CAMERAS

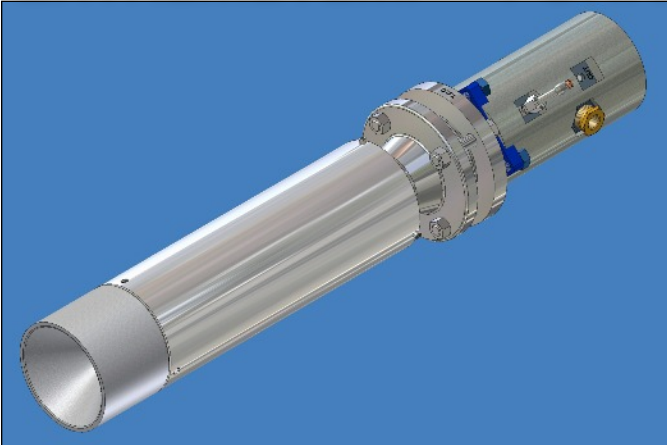

UNMATCHED PERFORMANCE

Canty EXTREME TEMP™ Cameras are ideal for demanding applications involving visual inspection or verification in extreme temperature environments.

- Computer designed optics for a crystal-clear picture.
- A digital electronic auto-iris provides an exceptional image of your application without the problems associated with manual apertures. Non-blooming CCD or Ethernet cameras.
- High temperature lenses designed to survive in process temperatures even in the event of air loss for short time periods.

SAFETY IS A PRIMARY CONCERN

Canty EXTREME TEMP™ Camera Systems feature a fused glass seal standard with every model. This unique seal provides an impenetrable safety barrier to protect the camera electronics from the harsh process environment.

ACCESSORIES

- This system provides the ability to remotely view a process that may not normally be watched. Multiple viewing stations may be linked to the system output so various departments may monitor a process.
- Ethernet systems allow the additional functionality of being able to remotely view through a Gigabit network system. Users can have access to live system images from their office networked computer.
- CANTYVISION™ software is available for customers that require additional functionality over simple viewing of a live image. Liquid level, position of an arc or ladle, and location of an ingot or bar are typical outputs customers utilize.
- The Canty Vector Control Module™ is available for use with Ethernet systems. For additional information see TA11500-1034.

FEATURES

- Replaceable ceramic nose cone
- Disposable quartz protective shield
- High temperature furnace lens - Process temp. to 3000° F
- Auto electronic iris
- High quality quartz optics
- Fused glass seal separates electronics from process
- Insertion lens available up to 36" long
- Non-blooming CCD or Ethernet cameras in an insulated electronics housing
- 100-1000 SCFH and 60-600 SCFH Flowmeters
- High intensity light filters and hot mirrors available

APPLICATIONS

- Furnaces
- Glass Production
- Plasma ARC Furnaces
- Incinerators
- Kilns
- Melting Chambers
- Vitrification

SPECIFICATIONS

- Video Formats: NTSC, PAL or Ethernet outputs available.
Video Output: 1.0 V p-p, 75 ohm (NTSC, PAL models) or Ethernet output to PC available
- Cable: RG59/U, RG11/U, RG6/U coaxial cable suitable for CCTV applications is recommended for analog cameras. Ethernet cameras require CAT5e or better cabling.
- Power Req.: User supplies 120 VAC, 60 Hz or 230 VAC, 50 Hz power. Canty supplies transformer to 12 VDC, .5A Typ.
- Ratings: Available in NEMA 4x or IP66 enclosures
- Mountings:
- 6" clearance hole into an insulation block when mounted horizontally with adequate system support.
 - Weld on sleeved collar for attachment to curved walls and allows for insertion length adjustment.
 - 6", 150# ANSI flange for sealed mount Requirements
- Requirements: Electronics housing-supply 90 PSI, 8 SCFM clean, dry instrument air.
Insertion lens - may require 13 SCFM clean, dry gas depending on application.

CANTY

Buffalo, NY USA
Ph: (716) 625 4227

Dublin, Ireland
Ph: + 353 (01) 882 9621

Phuket, Thailand
Ph: + 66 (83) 968 9548

DIMENSIONAL INFORMATION

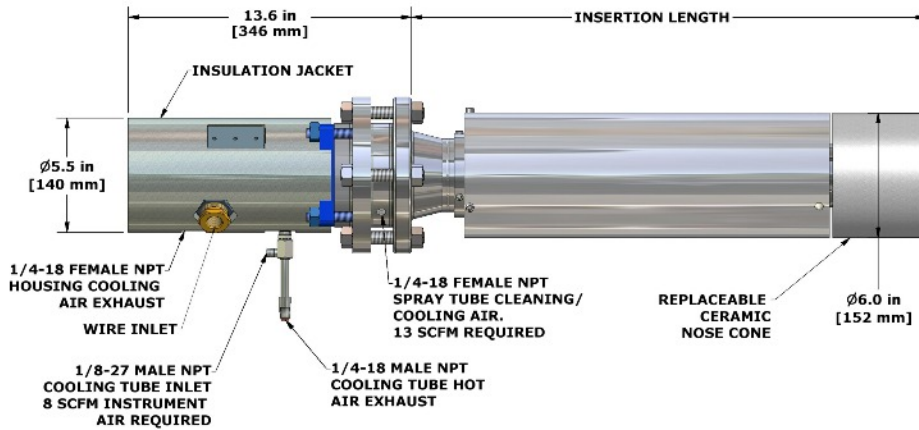

Dimensional Information For Diagram and Part Number Selection	
Combined Refractory/ Wall thickness	Insertion Length
6" - 16"	24"
17" - 30"	36"

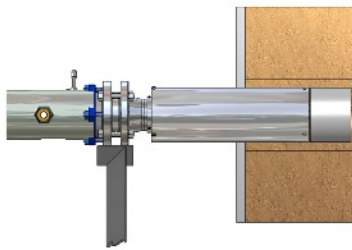

6H - MOUNT CONFIGURATION

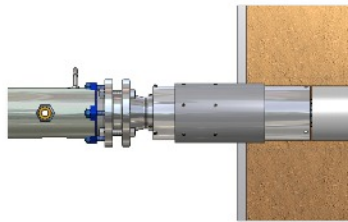

6C - COLLAR MOUNT CONFIGURATION

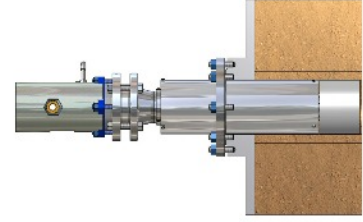

6F - 6", 150# CLASS FLANGE MOUNT CONFIGURATION

Notes:

1. 6H Mounting Configuration requires a 6.1" hole through the outer wall and refractory. Customer provides support brackets to hold camera in required position. Customer must seal the joint between the camera and shell while in position.
2. 6C Mounting Configuration requires a 6.1" hole through the refractory and 6.7" counterbore for the included mounting collar to slip into. Once in position the customer welds the collar to the outer shell. Customer must seal the joint between the camera and collar while in position. Includes mounting collar and setscrews.
3. 6F Mounting Configuration requires a 6.1" hole through the outer wall and refractory. Customer welds included carbon steel stud pad to the outer shell. Customer then welds the stainless steel mount flange to the camera to create the appropriate insertion length. Includes stud pad, mounting flange, hardware and gasket.
4. For installation manual see TA8823-1.PDF.

Ordering Information

HOW TO ORDER: Select the appropriate symbols and build a part number as shown:

EXAMPLE:

VSH DC 6 8 C 1 - S - 6C - 24INS

