

Ultrasonic Point Level Switches

Ultrasonic point level switches

are a cost-effective solution for your applications. Installation requires mounting the sensor (threaded or flanged) to the vessel, connecting the power and control wires, and applying power. There is no additional set-up or calibration required. Since it is an electronic instrument with no moving parts, preventive maintenance is limited to an annual visual inspection. The only recommended spare part is the “board” at a quantity of one board for every 10 units. A technician with basic electrical skills (wiring) can service the instrument.

Why use an ultrasonic switch over other level technologies? Depending upon your application, there may be three or four technologies equally suited for your application; however, only one will be the best choice when considering its features and benefits.

Features & Benefits

Cost

- In addition to the price of the instrument, you must consider the cost of installation, set-up and calibration.

Maintenance

- You need to factor in the frequency of preventative maintenance. Also, consider the cost of keeping key “spare parts” on the shelf.

Skill

- What “skill” level is required of your maintenance personnel to service the instrument.



701 Single Point



711 Single Point



722 Dual Point

Ultrasonic switches are simple to apply and use. There are only a few limitations to their use:

- The media must be liquid
- Process temperature between -40 and 250°F (-40 to 121°C)
- The media must have less than 5% suspended solids
- No aeration in fluids with a viscosity of 100cP (30W motor oil) or greater

The following chart will assist you in selecting the right product for your application.

Single-Point Sensing	Line Power		Loop Power
Integral Mount Electronics	701 Pages 4-5	711 Pages 6-7	701 Pages 4-5
Integral Mount Electronics with Sensor Monitor (Self-Test)	721 Pages 8-9		721 Pages 8-9
Remote Mount Electronics	701 Pages 4-5	711 Pages 6-7	701 Pages 4-5
Remote Mount Electronics with Sensor Monitor (Self-Test)	721 Pages 8-9		721 Pages 8-9
Dual-Point Sensing	Line Power		Loop Power
Alarm or Pump Control	712 Pages 10-11		N/A
Alarm or Pump Control with Sensor Monitor (Self-Test)	722 Pages 12-13		N/A

Principle

An ultrasonic switch is a device that uses inaudible high-frequency sound (ultrasound) to detect the presence or absence of a liquid at a designated point. The device consists of an electronic control unit and a sensor.

Ultrasonic level switches use the properties of sound transmission in vapor and liquids to detect liquid level. When sound travels in air, it loses a great deal of signal strength. When traveling in liquid, sound retains almost all of its signal strength.

To detect liquid level, we must determine if there is a liquid or gas (air) in the gap. Since liquids have a higher density than gasses, it is easier to transmit sound through them. One side of the sensor gap transmits sound, the other side detects it. When liquid is present, a high amount of sound is received at the detection side. When gas (air) is present, a small amount of sound is received. The electronics detect this difference and switch a relay accordingly.

Ultrasonic switch sensors contain two piezoelectric crystals, one transmits sound and one receives sound. Each crystal is mounted on one side of a gap in the metal sensor. The transmit crystal generates high frequency sound (1MHz to 3 MHz) that is directed across the gap to the receiver crystal. The receiver crystal converts the sound energy received into an electric signal, which is processed by the electronics to determine if the gap has liquid or air in it.

The drawing below shows the basic construction of an ultrasonic level switch sensor. An electrical signal is sent to the “transmit” crystal, which causes it to vibrate and produce high frequency sound. The “receive” crystal converts the high frequency sound that strikes it to another electrical signal, which is sent back to the electronics for processing. The sound energy that makes it across the sensor gap is very weak in air, and becomes very strong in liquid.

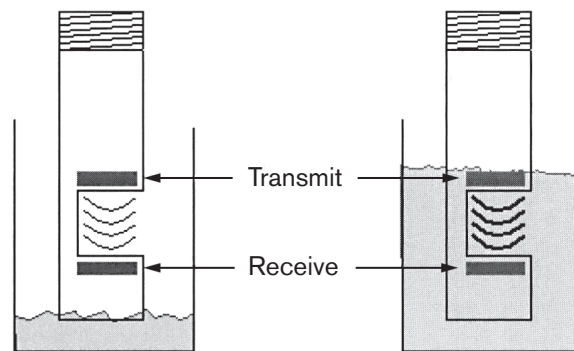

Application Conditions

Ultrasonic level switches can be used in a wide variety of applications without any calibration or setup. However, there are limitations to the types of process they will work in. The factors below must be taken into consideration before selecting an ultrasonic level switch for your application.

- Liquids only - the process media must be a liquid. The ultrasonic level switch cannot detect the difference between two gases or a gas and a solid. The even density of a liquid is required for proper detection.
- Clean liquids only - a liquid that has too high a percentage of solids will not transmit sound well enough to allow detection. Typically 5% suspended solids are the maximum amount allowed.
- The liquid must flow - an application where the liquid cannot drain out of the sensor gap will cause false alarms. If a liquid is too viscous to flow out of a 3/4" gap then the unit will not operate properly. Sometimes this can be solved by different mounting, but some liquids are just too viscous.
- No (or few) bubbles - especially in fluids with a viscosity higher than 100cP (30W motor oil). Large bubbles in thick fluids will block the sound signal from crossing the gap. Low viscosity fluids can have a fairly large amounts of bubbles as they tend to be very small (Alka-Seltzer in water).

If these guidelines are properly observed, the ultrasonic level switches will provide trouble-free operation without any calibration or periodic adjustment.

The 701 tip-sensitive ultrasonic switch

is a single-point device designed for economical detection of clean liquids. There are no moving parts and no calibration. The 701 is available either integral or remote mounted. An optional time delay can be used to eliminate false alarms due to turbulence in the process. An optional field selectable fail-safe switch is also available. The standard unit is set to High-level Failsafe (HLFS)

Features

- No calibration required
- 10A DPDT relay output
- FM Approved or CSA Certified for hazardous locations
- Line and loop powered versions
- Rostechnadzor (RTN) standard certificate (available upon request)



701 Single Point

Product Specifications			
Input Power			
Line	120 VAC, 50/60 Hz		
	240 VAC, 50/60 Hz		
	24 VDC		
Loop	11-36 VDC Intrinsically Safe		
Fuses	Field replaceable (line power only)		
Output Type			
Line	10A DPDT, 250 VAC		
	10A DPDT, 30 VDC		
	DC rating shown for resistive loads		
Loop	8mA (dry),		
	16 mA (Wet)-Standard		
Loop Resistance	765 ohms maximum @ 24 VDC		
Repeatability	0.078" (2mm)		
Failsafe	HLFS-Standard; field selectable is optional		
		Maximum Current Draw (Line Power)	
		24 VDC	100 mA
		120 VAC	35 mA
		240 VAC	18 mA
		Response Time	
		On	0 second
		Off	1 second
		Enclosure Environmental Rating	NEMA 4X; IP65
		Conduit Connection	3/4" NPT
		Maximum Remote Distance from Sensor	50 feet (15.2 meters)
		Ambient Temperature Range	-40 to 160°F (-40 to 71°C)
		Process Temperature Range	-40 to 250°F (-40 to 121°C)
		Maximum Process Pressure	2000 psig (138 bar)
		Weight*	2.5 lbs. (1.2 kg)

* See page 23 for sensor weights.

Model Number System

701-K1-U-P7-C-FS

The 701 is comprised of two parts. The first is the electronics and housing; the second is the sensor. Select the electronics and housings on this page and refer to page 18 for the sensor model number. The housing dimensions can be seen on pages 14 & 15. When ordering a remote housing, order remote cable part number 300-XX-S (XX = length in feet). Orders must have complete model numbers, i.e. each component must have a designator.

* Match sensor approvals to electronics approvals to maintain the agency listing integrity.

<div style="background-color: #003366; color: white; padding: 5px; text-align: center; font-weight: bold; font-size: 1.2em;">1</div> <div style="background-color: #003366; color: white; padding: 5px; text-align: center; font-weight: bold; font-size: 1.2em;">Electrical Housing</div> <ul style="list-style-type: none"> Integral K1 Remote R1 Integral (9 Power Only) K4 Remote (9 Power Only) R <p>(order remote cable part number 300-XX-S, XX = length in feet - max 50 feet)</p>	<div style="background-color: #003366; color: white; padding: 5px; text-align: center; font-weight: bold; font-size: 1.2em;">2</div> <div style="background-color: #003366; color: white; padding: 5px; text-align: center; font-weight: bold; font-size: 1.2em;">Power Supply</div> <ul style="list-style-type: none"> 24 VDC (K1 and R1 housings only) 6 120 VAC (K1 and R1 housings only) 7 240 VAC (K1 and R1 housings only) 8 24 VDC (Loop) 9 (K4 and R4 housings only) 	<div style="background-color: #003366; color: white; padding: 5px; text-align: center; font-weight: bold; font-size: 1.2em;">3</div> <div style="background-color: #003366; color: white; padding: 5px; text-align: center; font-weight: bold; font-size: 1.2em;">Accessories</div> <ul style="list-style-type: none"> AI CSA Certified Intrinsically Safe* (9 power only) (K4 housings only) BK Remote electronics flat surface mounting bracket (R housings only) (see pages 14 & 15) CS CSA Certified Explosion Proof* CV Canadian Registration Number (CRN) Process ratings may be affected. Consult the factory for details FI FM Approved Intrinsically Safe* (9 power only) (K4 housings only) FM FM Approved Explosion Proof* FS Field selectable Failsafe switch (6, 7, 8 power only) OD On delay time (6, 7, 8 power only) (specify time from chart on page 16) OF Off delay timer (6, 7, 8 power only) (specify time from chart on page 16) PK Pipe mounting kit, BK accessory required (R housing only) (see page 17) PP Fiber tag with customer specified tag information PY Powder coat epoxy coating applied to housing exterior RG Gold-contact relay (6, 7, 8 power only) RR SS nameplate wired to the unit with customer specified tag information TT SS nameplate permanently affixed to housing with customer specified tag information VV Fungicidal varnish applied to housing exterior YY Epoxy coating applied to housing exterior (200 hours - salt spray) 				
701	K1	U	P7	C	FS	← Model Number

Agency Approval

Agency	Safety Method	Approval	Model(s)
FM	Explosion Proof	Class I, Groups C, D; Class II, Groups E, F, G; Class III, Division 1	701xx-U-Px-FM
	Intrinsically Safe	Class I, Groups C, D; Class II, Groups E, F, G; Class III, Division 1	701K4-U-P9-FI
CSA	Explosion Proof	Class I, Groups C, D; Class II, Groups E, F, G; Class III, Division 1	701xx-U-Px-CS
	Intrinsically Safe	Class I, Groups C, D; Class II, Groups E, F, G; Class III, Division 1	701K4-U-P9-AI



The **711 ultrasonic switch** is a versatile single-point device designed for the detection of clean liquids. The 711 is available with a variety of sensor types to meet most process conditions. It is available integral or remote mounted and comes standard with field-selectable failsafe.

Features

- No calibration required
- Can be used with notch type sensors
- FM Approved and CSA Certified, for hazardous locations
- Field-selectable failsafe
- Rostechnadzor (RTN) standard certificate (available upon request)



711 Single Point

Product Specifications				
Input Power	120 VAC, 50/60 Hz	Response Time		
	240 VAC, 50/60 Hz		On	250 mSec
	24 VDC		Off	250 mSec
Output Type	10A DPDT, 250 VAC	Enclosure Environmental Rating	NEMA 4X; IP65	
	10A DPDT, 30 VDC		Conduit Connection	3/4" NPT
	DC rating shown for resistive loads			
Repeatability	0.078" (2mm)	Maximum Remote Distance from Sensor	50 ft. (15.2 m)	
Failsafe	Field-selectable	Ambient Temperature Range	-40 to 160°F (-40 to 71°C)	
Maximum Current Draw (Line Power)		Process Temperature Range	-40 to 250°F (-40 to 121°C)	
	24 VDC		140 mA	
	120 VAC		60 mA	
	240 VAC	30 mA		
		Maximum Process Pressure	2000 psig (138 bar)	
		Weight*	2.5 lbs. (1.2 kg)	

*See page 23 for sensor weights.

Model Number System

711-K1-N-P6-C-PP

The 711 is comprised of two parts. The first is the electronics and housing; the second is the sensor. Select the electronics and housings on this page and refer to page 18 for the sensor model number. The housing dimensions can be seen on pages 14 & 15. When ordering a remote housing, order remote cable part number 300-XX-S (XX = length in feet). Orders must have complete model numbers, i.e. each component must have a designator.

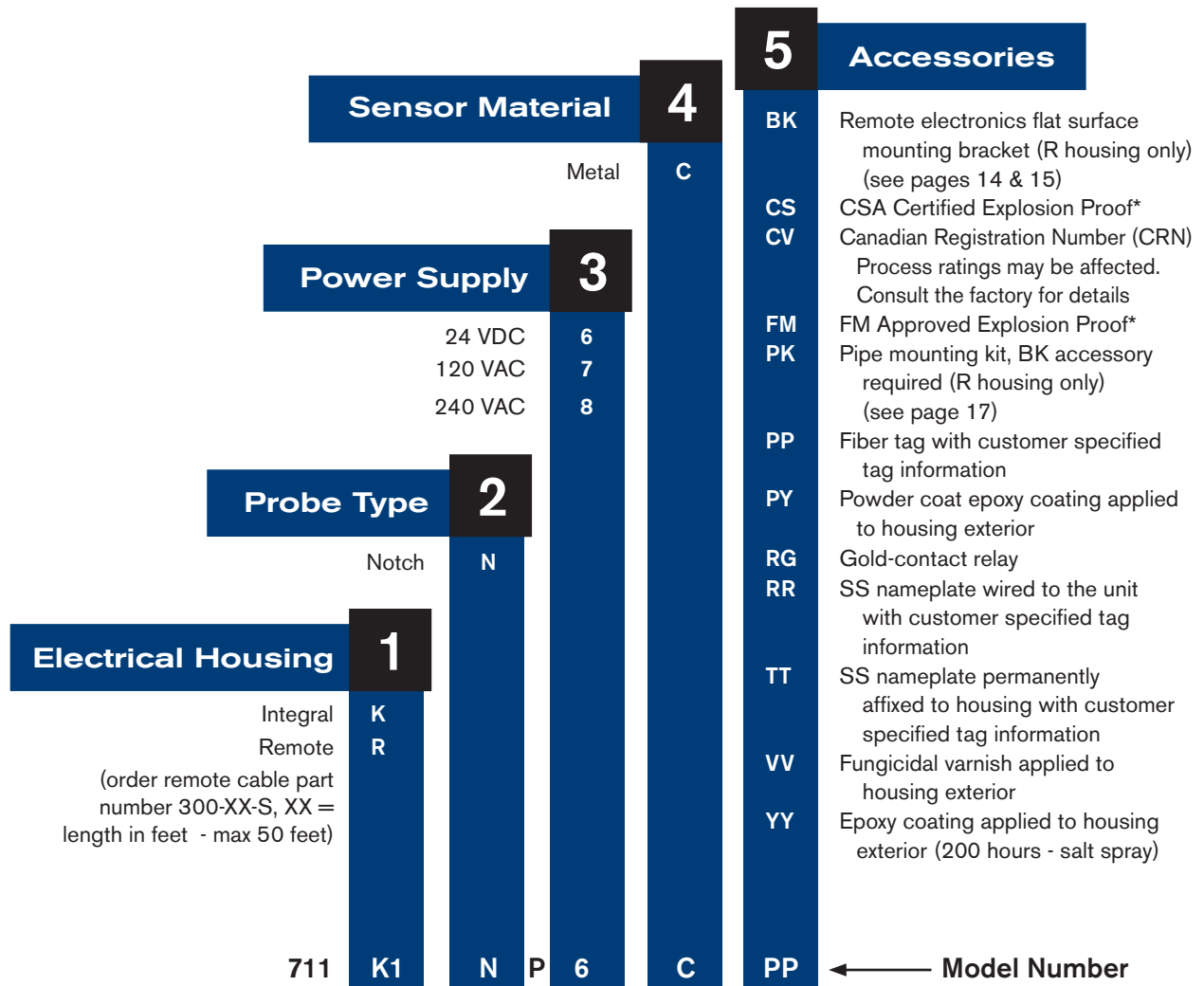

* Match sensor approvals to electronics approvals to maintain the agency listing integrity.

Agency Approvals

Agency	Safety Method	Approval	Model(s)
FM	Explosion Proof	Class I, Groups C, D; Class II, Groups E, F, G; Class III, Division 1	711x1-N-Px-FM
CSA	Explosion Proof	Class I, Groups C, D Class II, Groups E, F, G; Class III, Division 1	711x1-N-Px-CS



The **721 ultrasonic switch** is an advanced single-point device designed to meet your needs for overfill protection. In addition to the features of the 711, the 721 includes a “Sensor Monitor.” This circuit continuously tests the functionality of the electronics and sensor. The “Sensor Monitor Relay” de-energizes if a fault is detected. The 721 is available with a variety of sensor types to meet most process conditions. It is available integral or remote mounted and comes standard with field-selectable failsafe.



721 Single Point

Features

- No calibration required
- Continuous self-test (sensor monitor) verifies operation
- FM or CSA Certified for hazardous locations
- Field-selectable failsafe
- On/Off time delay is standard
- Rostechnadzor (RTN) standard certificate (available upon request)

Product Specifications			
Input Power		Maximum Current Draw (Line Power)	
Line		24 VDC	220 mA
	120 VAC, 50/60 Hz	120 VAC	60 mA
	240 VAC, 50/60 Hz	24 VDC	30 mA
	24 VDC		
Loop		Response Time (Line Power)	
	11-36 VDC	On	250 mSec
	(Intrinsically safe)	Off	250 mSec
Output Type		Response Time (Loop Power)	
Line		On	0.5 seconds
	Alarm	Off	5 seconds
	10A DPDT, 250 VAC		
	10A DPDT, 30 VDC		
	DC rating shown for resistive loads		
		Time Delay	0-30 seconds
	Sensor Monitor		
	10A DPDT, 250 VAC	Enclosure Environmental Rating	NEMA 4X; IP65
	10A DPDT, 30 VDC		
	DC rating shown for resistive loads	Conduit Connection	3/4" NPT
Loop		Maximum Remote Distance from Sensor	50 ft. (15.2 m)
	Alarm	8 mA (Dry), 16 mA (Wet)	
	Sensor Monitor	5 mA or 19 mA; Field selectable	
		Ambient Temperature Range	-40 to 160°F (-40 to 71°C)
Loop Resistance	650 ohms maximum @ 24 VDC	Process Temperature Range	-40 to 250°F (-40 to 121°C)
Repeatability	0.078" (2mm)	Maximum Process Pressure	2000 psig (138 bar)
Failsafe	Field-selectable	Weight*	3 lbs. (1.4 kg)

*See page 23 for sensor weights.

Model Number System

721R2-N-P7-C-FM

The 721 is comprised of two parts. The first is the electronics and housing; the second is the sensor. Select the electronics and housings on this page and refer to page 18 for the sensor model number. The housing dimensions can be seen on pages 14 & 15. When ordering a remote housing, order remote cable part number 300-XX-S (XX = length in feet). Orders must have complete model numbers, i.e. each component must have a designator.

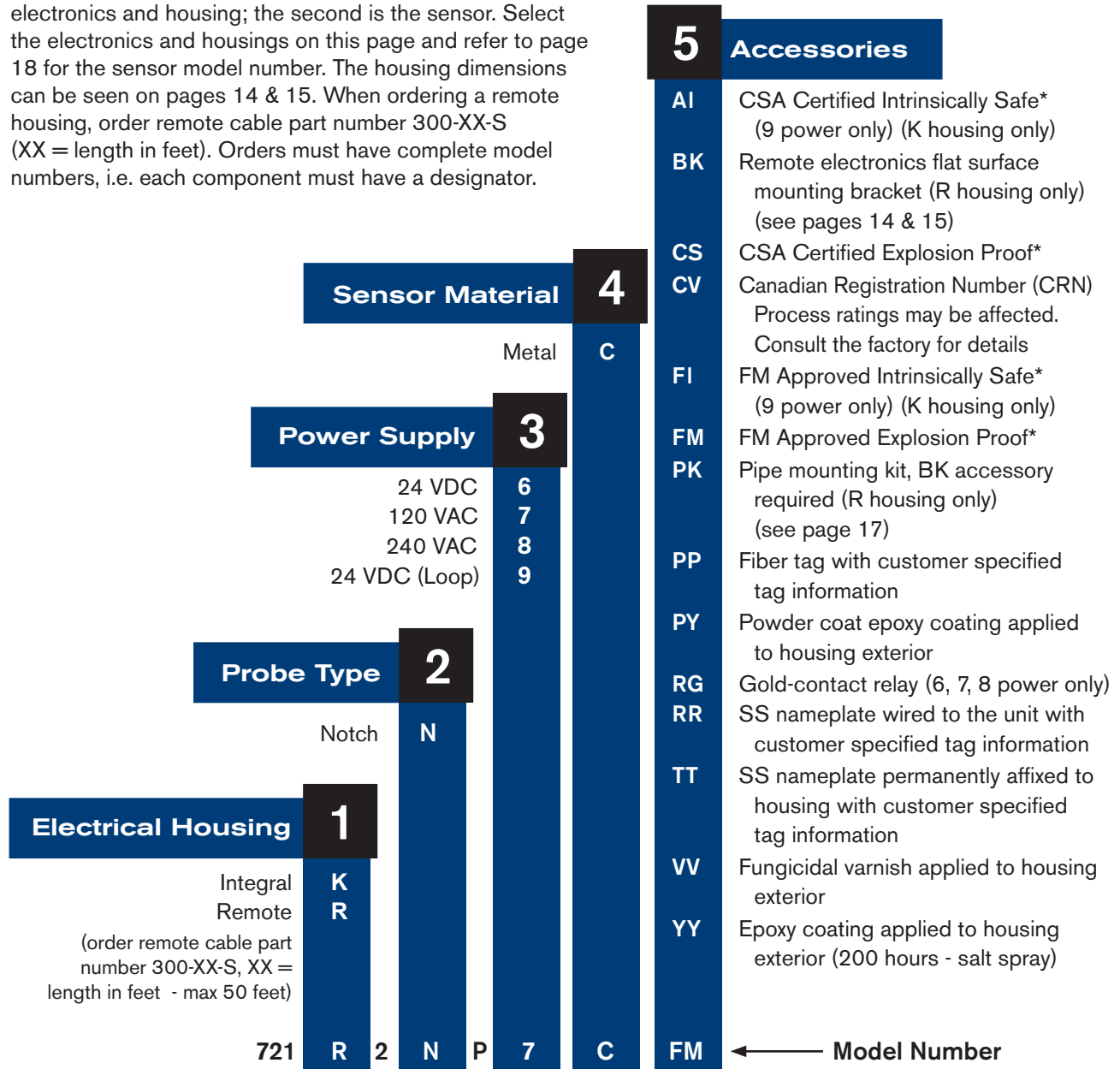

*Match sensor approvals to electronics approvals to maintain the agency listing integrity

Agency Approvals

Agency	Safety Method	Approval	Model(s)
FM	Explosion Proof	Class I, Groups C, D; Class II, Groups E, F, G; Class III, Division 1	721x2-N-Px-FM
	Intrinsically Safe	Class I, Groups C, D; Class II, Groups E, F, G; Class III, Division 1	721K2-N-P9-FI
CSA	Explosion Proof	Class I, Groups C, D Class II, Groups E, F, G; Class III, Division 1	721x2-N-Px-CS
	Intrinsically Safe	Class I, Groups C, D Class II, Groups E, F, G; Class III, Division 1	721K2-N-P9-AI



The **712 ultrasonic switch** is a versatile dual-point designed for the detection of clean liquids. The dual-output can be used as independent alarm points or used in tandem to provide pump control. It is available integral or remote mounted and comes standard with field-selectable failsafe.

Features

- No calibration required
- Optional pump control logic available
- FM and CSA Certified for hazardous locations
- Field-selectable failsafe



712 Dual Point

Product Specifications			
Input Power		Enclosure Environmental Rating	NEMA 4X; IP65
Line	120 VAC, 50/60 Hz	Conduit Connection	1" NPT
	240 VAC, 50/60 Hz	Maximum Remote Distance from Sensor	50 ft. (15.2 m)
	24 VDC	Ambient Temperature Range	-40 to 160°F (-40 to 71°C)
Output Type	(2) 10A DPDT, 250VAC	Process Temperature Range	-40 to 250°F (-40 to 121°C)
	(2) 10A DPDT, 30VDC	Maximum Process Pressure	2000 psig (138 bar)
	DC rating shown for resistive loads	Weight*	7 lbs. (3.2 kg) + 10.5 lbs. (4.8 kg) for cast iron housing + 2 lbs. (1 kg) for remote
Repeatability	0.078" (2mm)		
Failsafe	Field-selectable		
Maximum Current Draw			
24 VDC	280 mA		
120 VAC	120 mA		
240 VAC	60 mA		
Response Time (Line Power)			
On	250 mSec		
Off	250 mSec		

*See page 23 for sensor weights.

Model Number System

712K3-N-P6-C-YY

712 ultrasonic switch with integral housing, 240VAC power supply, with optional epoxy coating.

The 712 is comprised of two parts. The first is the electronics and housing; the second is the sensor. Refer to page 19 for the sensor model number.

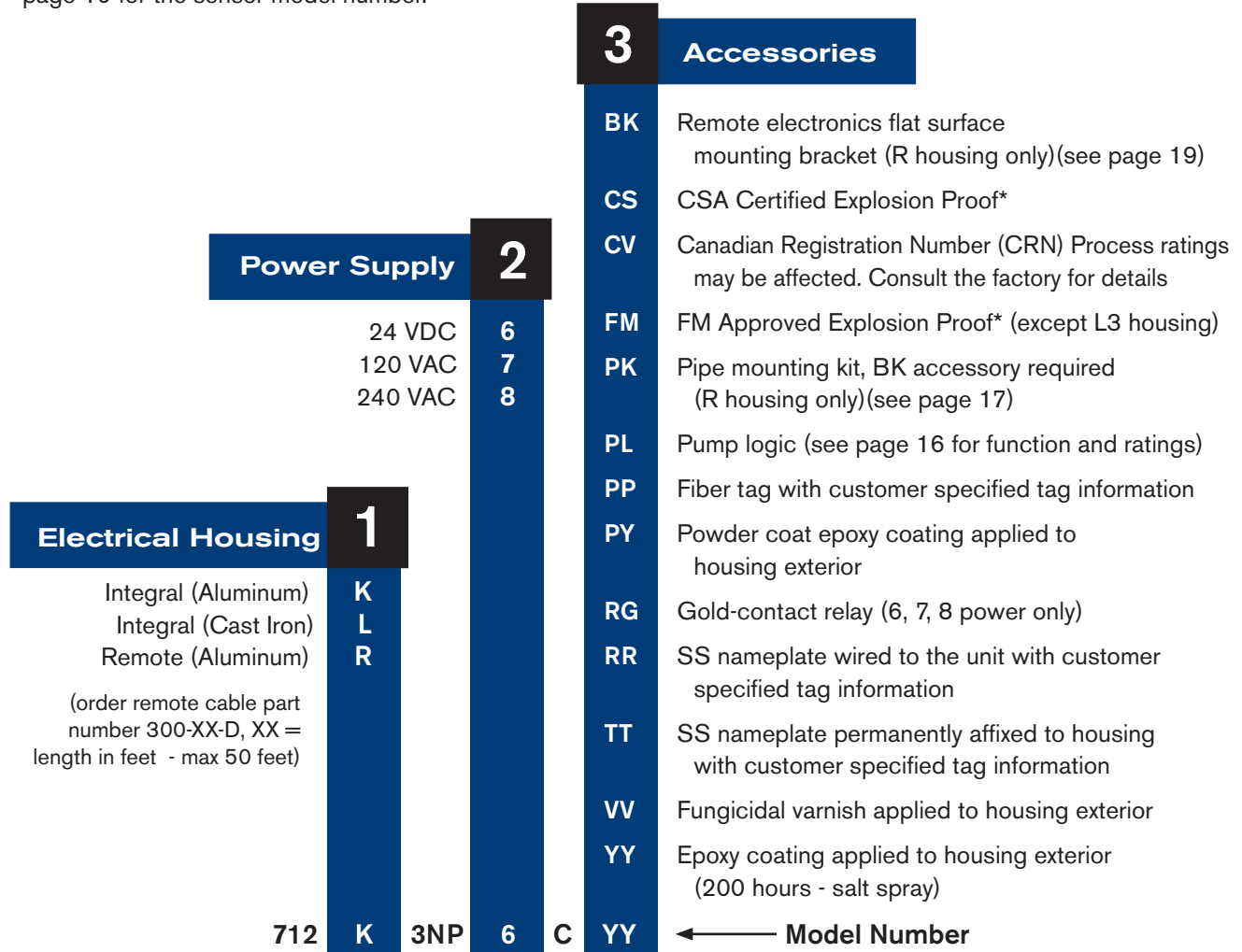

Agency Approvals

Agency	Safety Method	Approval	Model(s)
FM	Explosion Proof	Class I, Groups B, C, D; Class II, Groups E, F, G; Class III, Division 1	712K3-N-Px-FM
		Class I, Groups C, D; Class II, Groups E, F, G; Class III, Division 1	712R3-N-Px-FM
CSA	Explosion Proof	Class I, Groups C, D Class II, Groups E, F, G; Class III, Division 1	712K3-N-Px-CS 712L3-N-Px-CS
		Class I, Groups C, D Class II, Groups E, F, G; Class III, Division 1	712R3-N-Px-CS



The **722 ultrasonic switch** is an advanced dual-point device designed to meet your needs for sump/pump control. In addition to the features of the 712, the 722 includes a “Sensor Monitor.” This circuit continuously tests the functionality of the electronics and sensor (both gaps). The “Sensor Monitor Relay” de-energizes if a fault is detected. It is available integral or remote mounted and comes standard with field-selectable failsafe and time delay.

Features

- No calibration required
- Continuous self-test (sensor monitor) verifies operation of the unit
- FM and CSA Certified for hazardous locations
- Field-selectable failsafe
- On/Off time delay is standard
- Rostechnadzor (RTN) standard certificate (available upon request)



722 Dual Point

Product Specifications			
Input Power	Line	120 VAC, 50/60 Hz	Response Time
		240 VAC, 50/60 Hz	On 250 mSec
		24 VDC	Off 250 mSec
Output Type	Alarm	(2) 10A DPDT, 250 VAC	Time Delay
		(2) 10A DPDT, 30 VDC	0-30 seconds
		DC rating shown for resistive loads	Enclosure Environmental Rating
	Sensor Monitor	(2) 10A DPDT, 250 VAC	NEMA 4X; IP65
		(2) 10A DPDT, 30 VDC	Conduit Connection
		DC rating shown for resistive loads	1" NPT
Repeatability		0.078" (2mm)	Maximum Remote Distance from Sensor
Failsafe		Field-selectable	50 ft. (15.2 m)
Maximum Current Draw (Line Power)			Ambient Temperature Range
	24 VDC	440 mA	-40 to 160°F (-40 to 71°C)
	120 VAC	120 mA	Process Temperature Range
	240 VAC	60 mA	-40 to 250°F (-40 to 121°C)
			Maximum Process Pressure
			2000 psig (138 bar)
			Weight*
			7 lbs. (3.2 kg) + 10.5 lbs. (4.8 kg) for cast iron housing + 2 lbs. (1 kg) for remote.

*See page 23 for sensor weights.

Model Number System

722K3-N-P6-C-PL

722 ultrasonic switch with integral housing copper-free aluminum, 24VDC power supply, with optional pump logic

The 722 is comprised of two parts. The first is the electronics and housing; the second is the sensor. Refer to page 19 for the sensor model number.

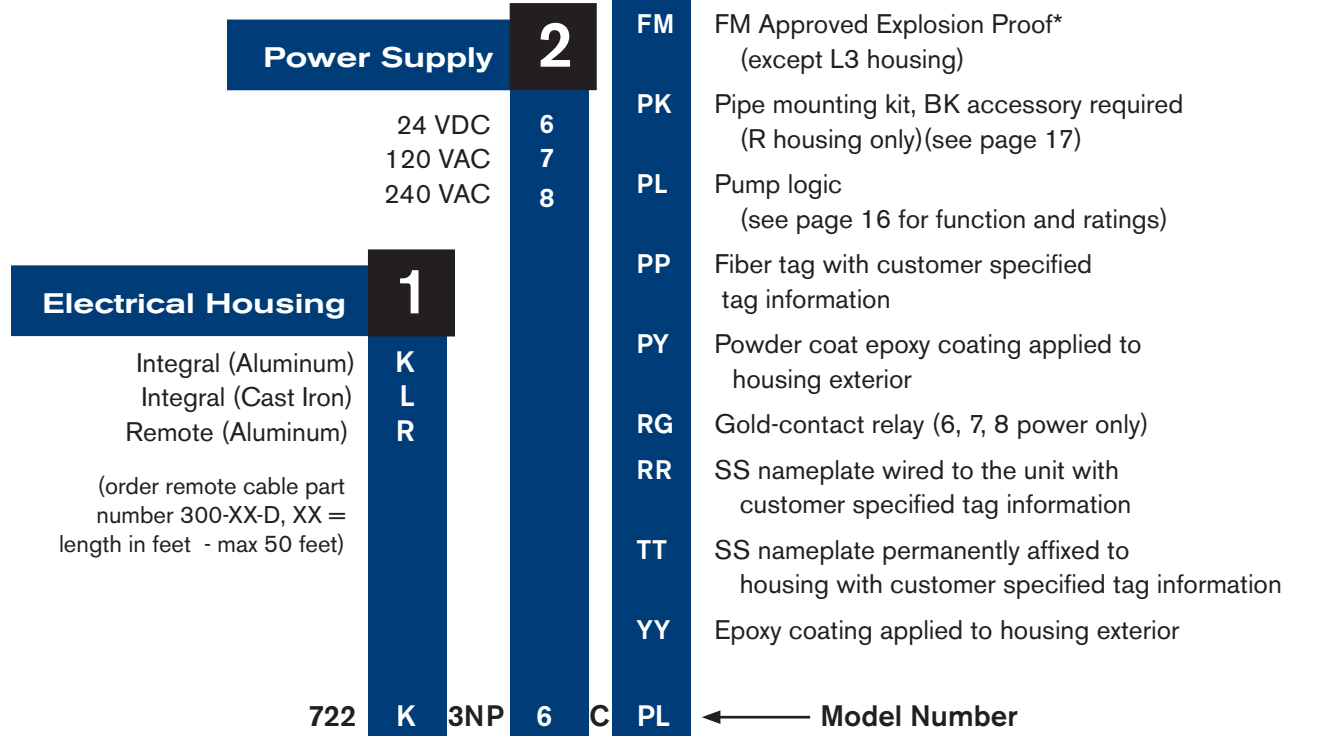

Agency Approvals

Agency	Safety Method	Approval	Model(s)
FM	Explosion Proof	Class I, Groups B, C, D; Class II, Groups E, F, G; Class III, Division 1	722K3-N-Px-FM
		Class I, Groups C, D; Class II, Groups E, F, G; Class III, Division 1	722R3-N-Px-FM
CSA	Explosion Proof	Class I, Groups B, C, D Class II, Groups E, F, G; Class III, Division 1	722K3-N-Px-CS 722L3-N-Px-CS
		Class I, Groups C, D Class II, Groups E, F, G; Class III, Division 1	722R3-N-Px-CS



Dimensions in this catalog are for reference only. They may be changed without notice. Contact the factory for certified drawings for a particular model number. Dimensions are expressed as millimeter over inches (Linear = mm/in.).

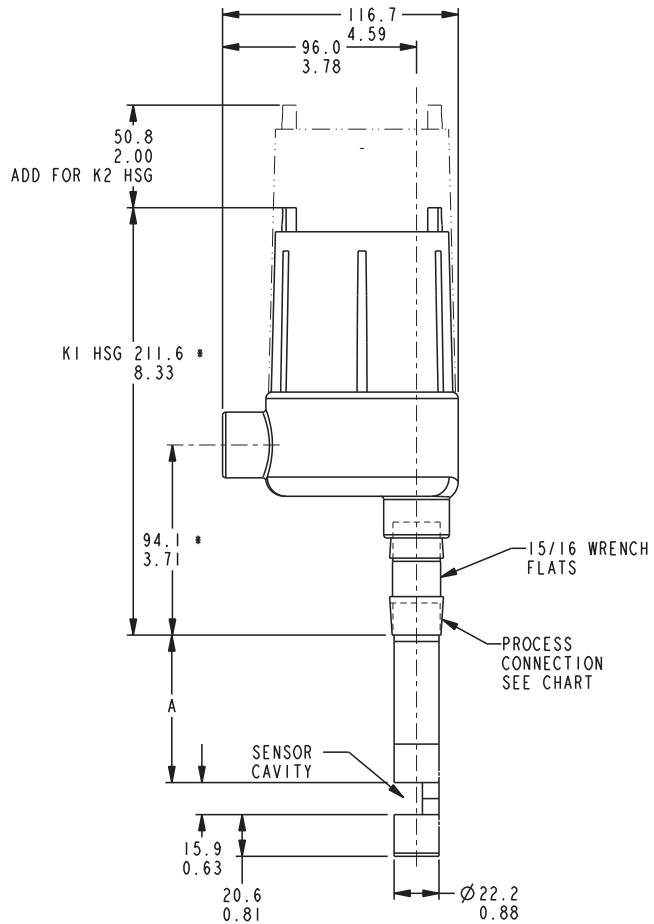

Housing: K1, K2

Drawing 0390000

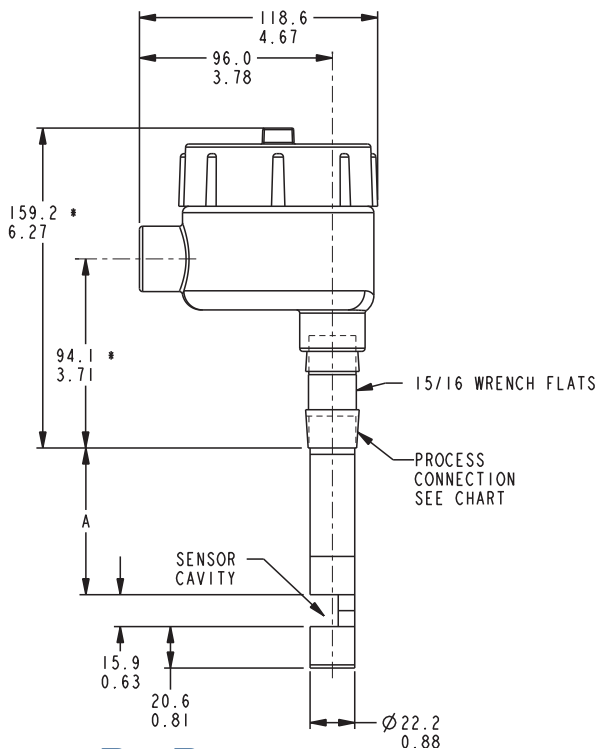

Housing: R1, R2

Drawing 0390034

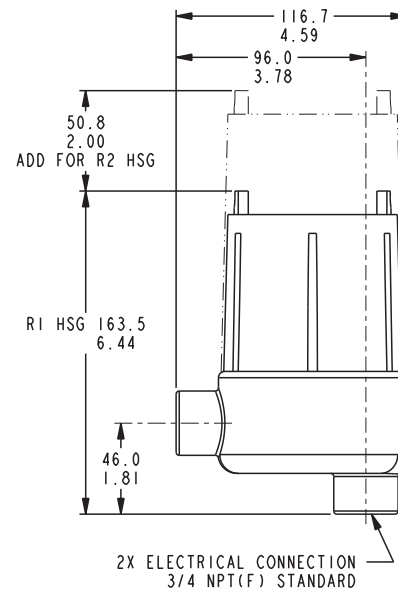

Process Connection	*Add to Length
3/4" NPT(M)	Shown
1" NPT(M)	Add $\frac{8.0}{.313}$
1-1/2" NPT(M) 2" NPT(M)	Add $\frac{9.5}{.375}$

Ultrasonic Switches

Dimensions

Dimensions in this catalog are for reference only. They may be changed without notice. Contact the factory for certified drawings for a particular model number. Dimensions are expressed as millimeter over inches (Linear = mm/in.).

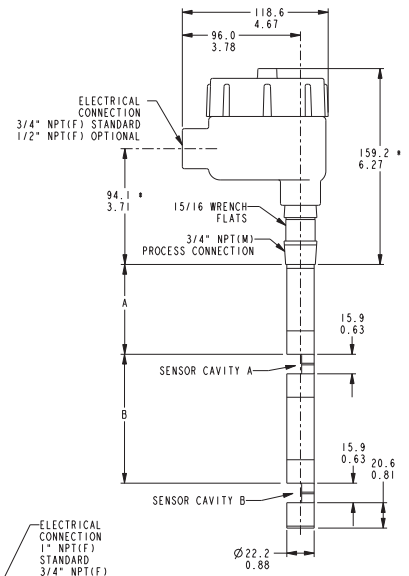
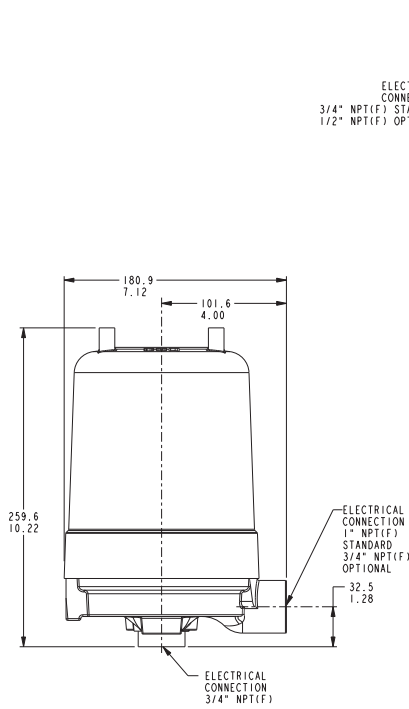
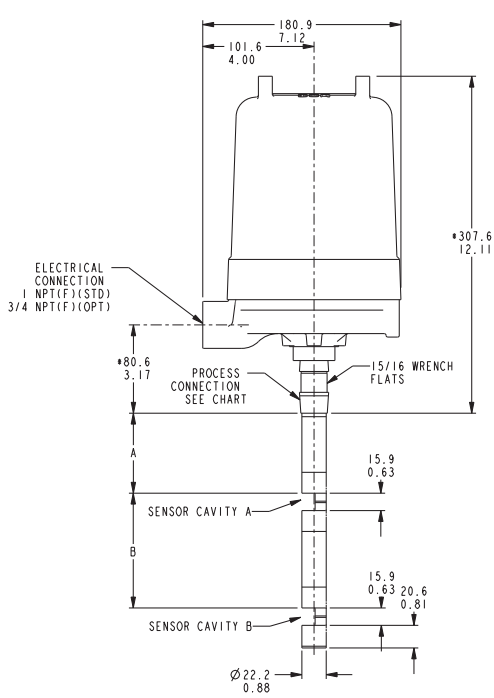

Housing: R3
Drawing 0390040

Housing: K3, L3
Drawing 0390029

Process Connection	*Add to Length
3/4" NPT(M)	Shown
1" NPT(M)	Add 8.0 .313
1-1/2" NPT(M) 2" NPT(M)	Add 9.5 .375

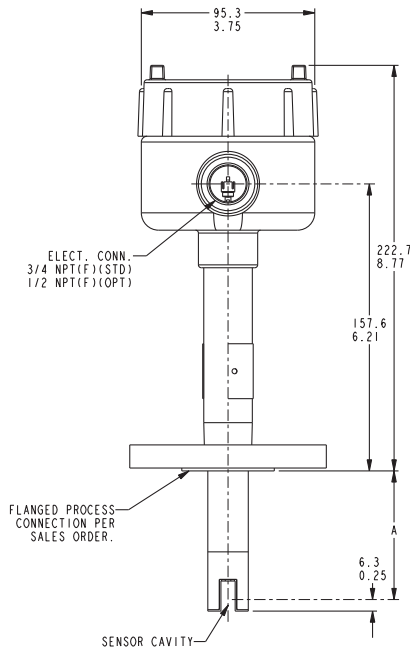

Housing: K4
Drawing 0390530

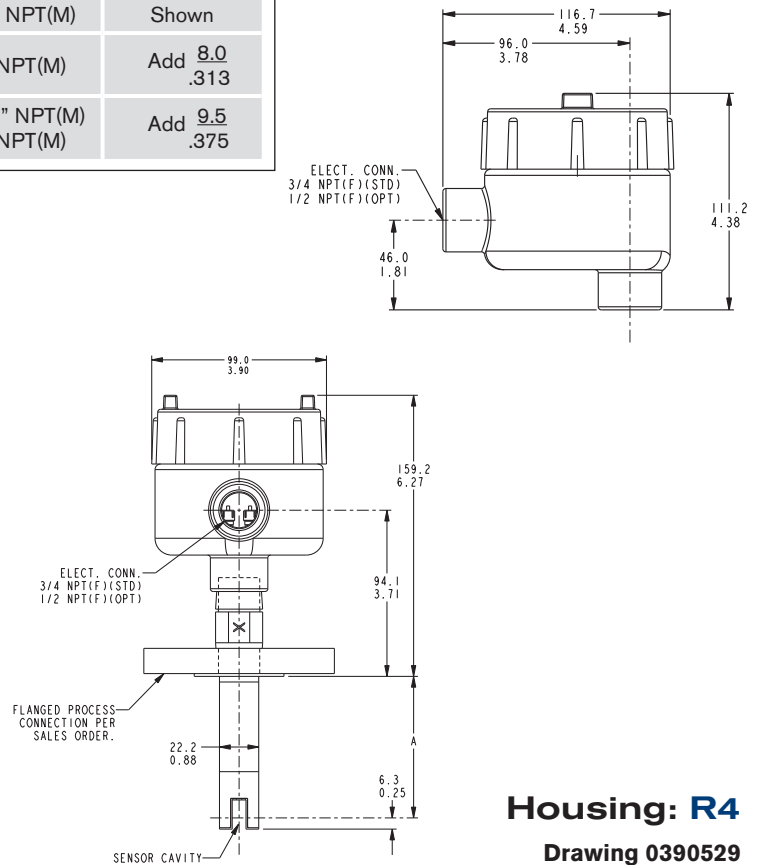

Housing: R4
Drawing 0390529

Two point ultrasonic level switches can be supplied with an on-board DPDT relay for pump control. The relay is rated 5 amp, 250 VAC; 5 amp, 30 VDC (resistive) and it can be field wet to pump up (left diagram) or pump down (right diagram).

Adding the pump logic (PL) accessory to the end of a model number changes level indication relays to SPDT and changes current requirements according to the table shown:

Supply Voltage	Maximum Current Draw
24 VDC	350 mA
120 VAC	120 mA
240 VAC	50 mA

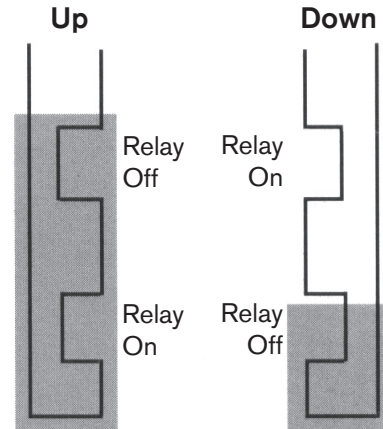

Time Delay

When using time delay accessory OD or OF, choose a standard time delay from the chart below. Include the time delay after the model number.

For example: 701K1-U-P6-C-OD
OD = 60 seconds.

Time Delay in Seconds (choose one)		
1	35	100
5	50	120
15	60	150
25	70	190

Approximate Weights*

Actual shipping weights may vary from charted values because of product material, configurations and packaging requirements. For remote electrical housing add 2 lbs. (1kg) to total weight.

Ultrasonic Series	Weight (lbs.)	(kgs)	Additional Weights
701, 711	2.5	1.2	---
721	3	1.4	---
712, 722	7	3.2	10.5 lbs. (4.8 kg) for cast iron housing

*See page 23 for sensor weights.

Drawing 0390062

Remote electronic housings are supplied for line mounting as a standard. Optional brackets are available for flat surface or pipe mounting.

The basic BK bracket can be adapted for mounting onto 1-1/2" to 2" pipe or stanchion by adding designator PK after BK.

For the basic flat surface mounting bracket, add designator BK to the end of any model number from the controls section in the front of this catalog. Linear = mm/in.

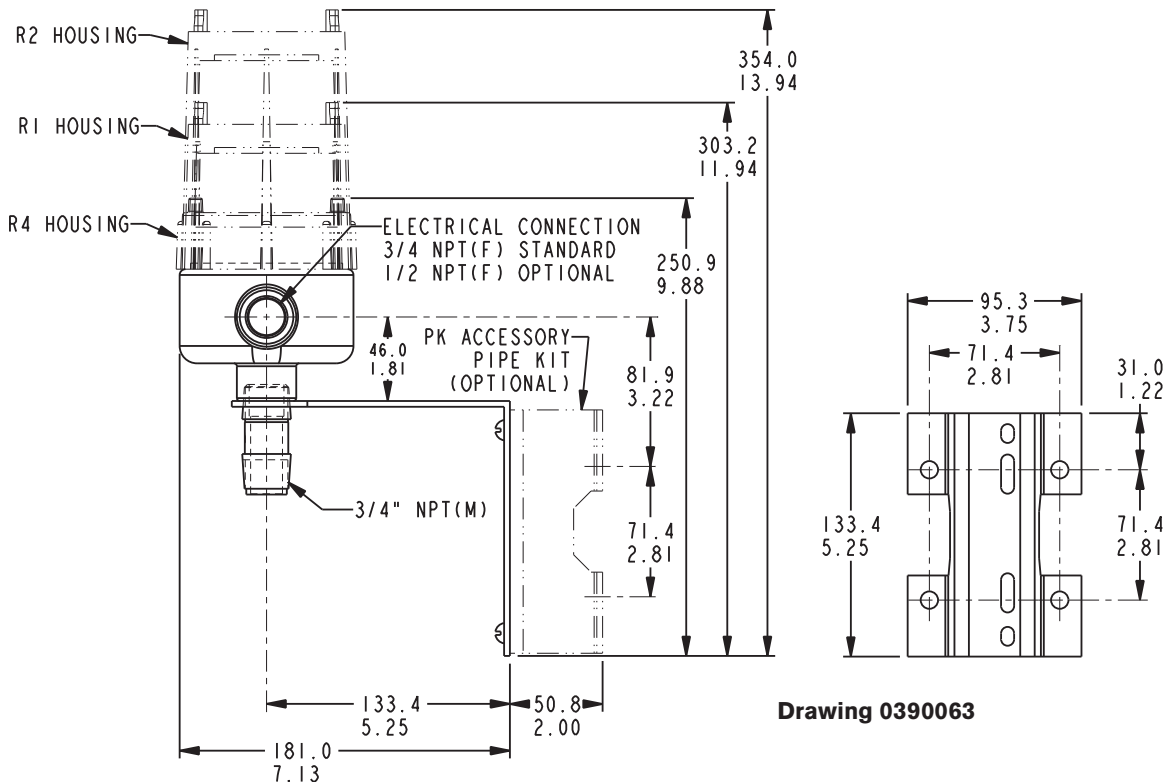
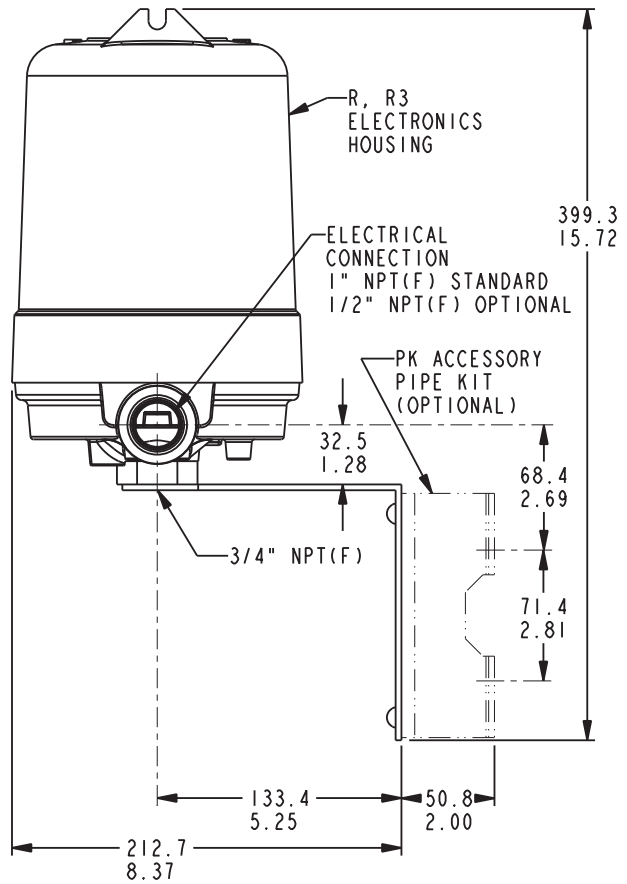

Drawing 0390063

Model Number System

371-U 2-C 3A-RR

The 371 sensor is designed for use with all single-point ultrasonic electronic unit.

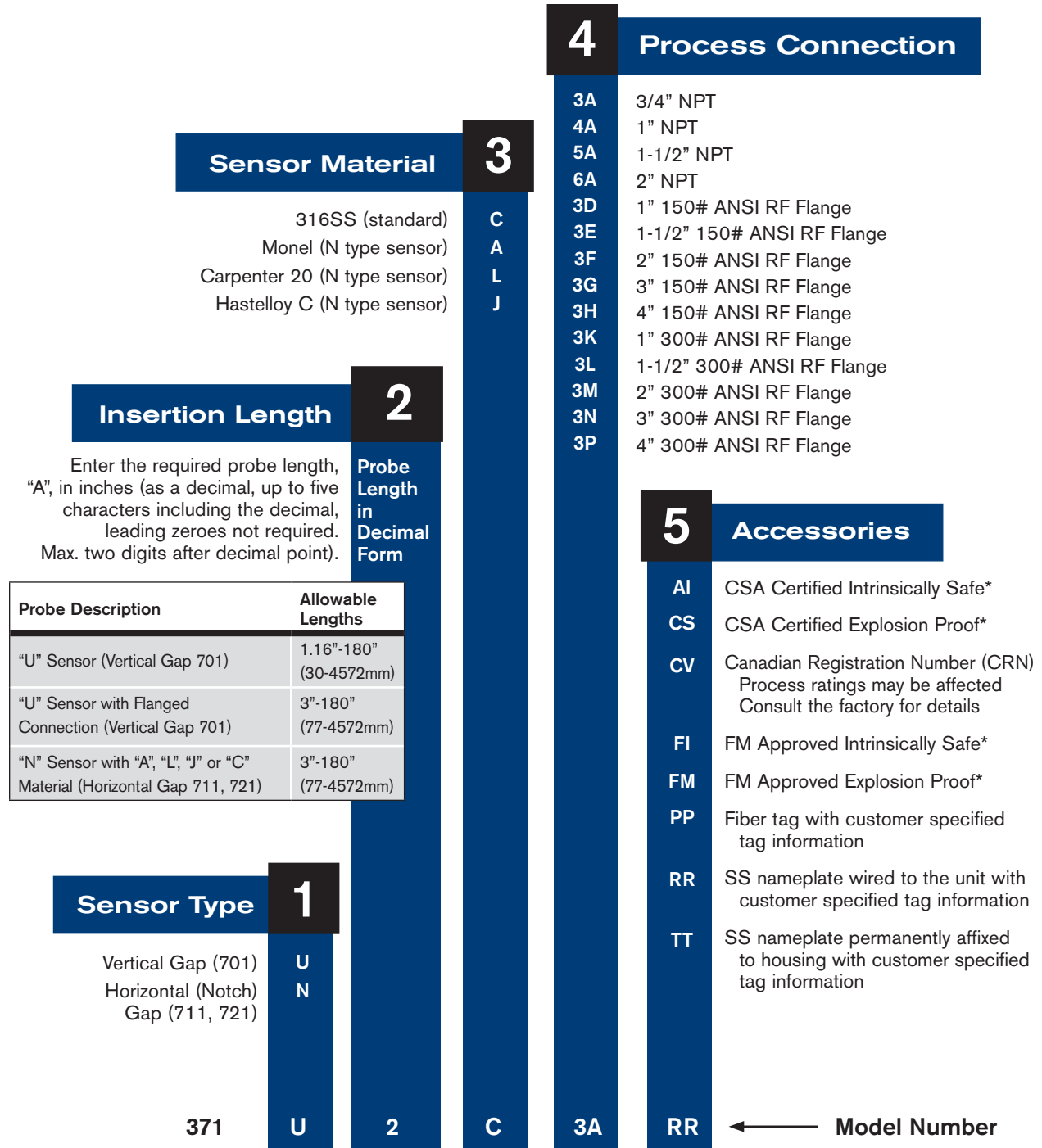

*Match sensor approvals to electronics approvals to maintain the agency listing integrity.

Model Number System

372-N 12-C3A-CS

The 372 sensor is designed for use with all dual-point ultrasonic electronic units.

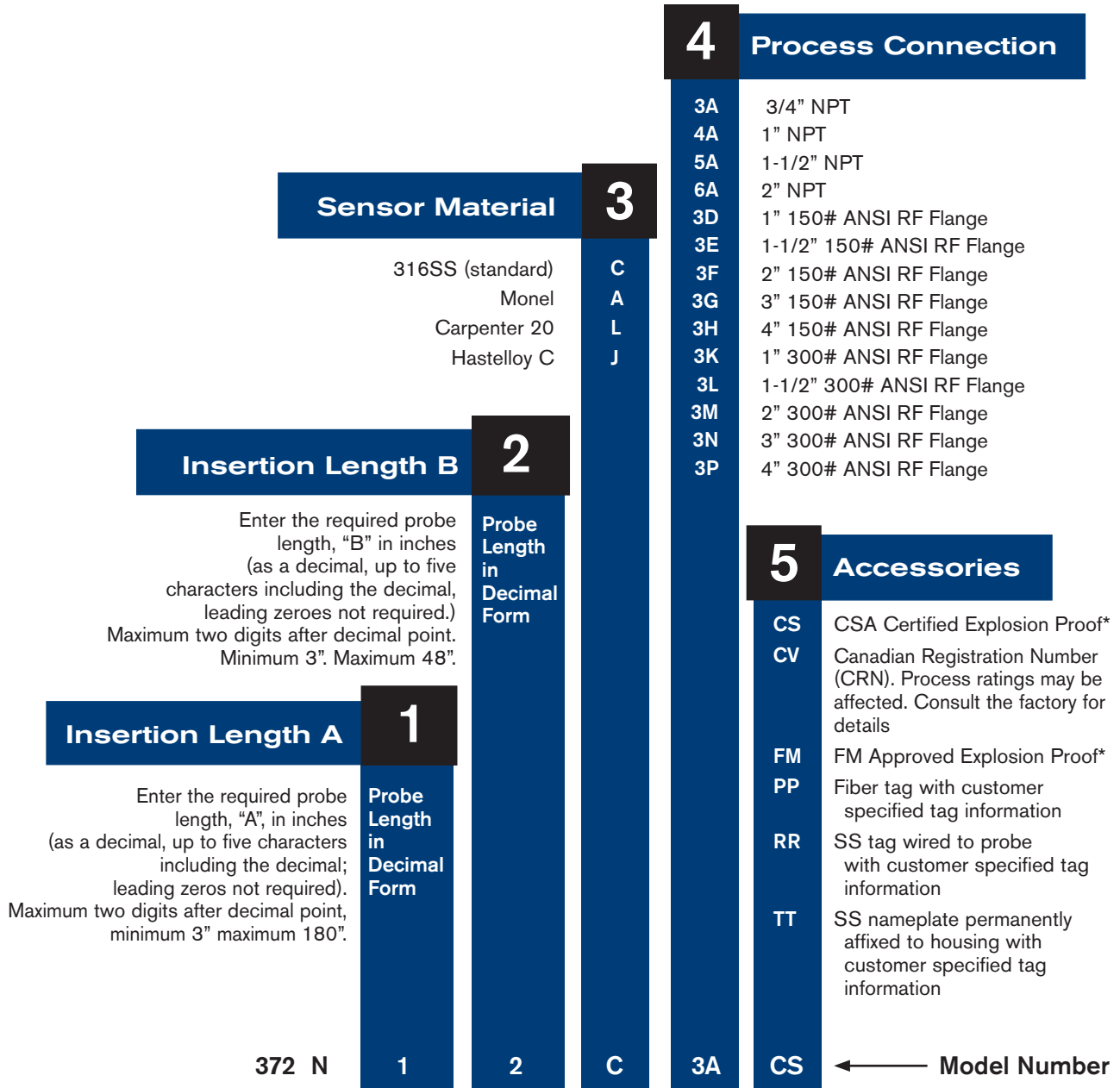

See page 23 for flange weights.

*Match sensor approvals to electronics approvals to maintain the agency listing integrity.

Ultrasonic Switches

Electronics

Certificates	Loop Power (P9)	Line Power (P6, P7, P8)	All Sensors
Calibration C1	◆	◆	
Hydrostatic Pressure Test C2			◆
Inspection Report C3	◆	◆	
Compliance / Conformance C4	◆	◆	
Insulation Resistance C6		◆	

Sensor Dimensions

Dimensions shown are for reference only. Contact the factory for certified dimension drawings.

Linear = mm/in.

Process Connection	*Add to Length
3/4" NPT(M)	Shown
1" NPT(M)	Add $\frac{8.0}{.313}$
1-1/2" NPT(M) 2" NPT(M)	Add $\frac{9.5}{.375}$

Type U Single Point (Threaded) Drawing 0390415

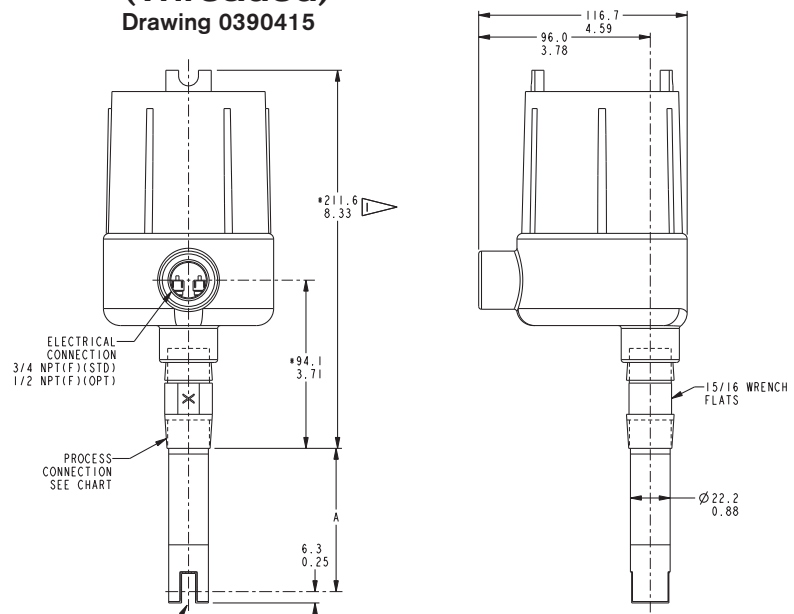

Type U Single Point (Flanged) Drawing 0390516

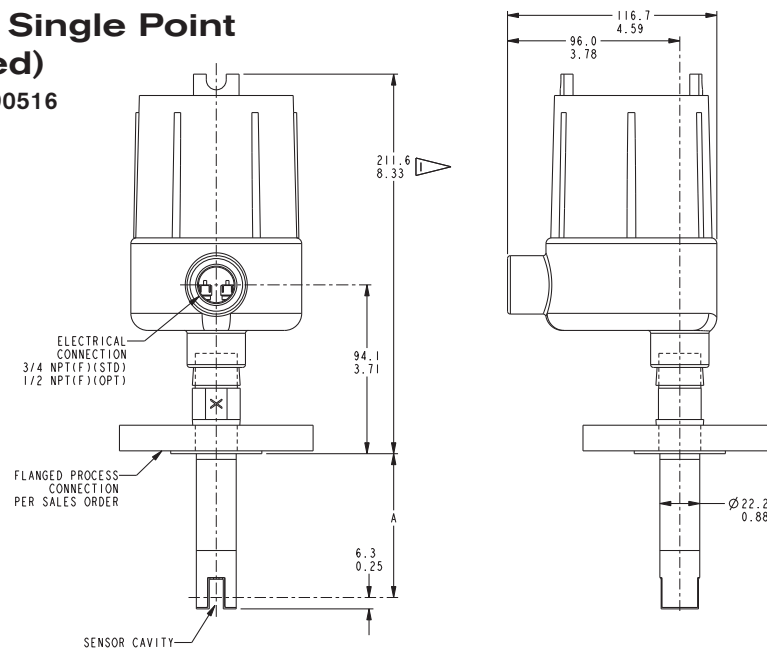

Dimensions shown are for reference only. Contact the factory for certified dimension drawings.

Linear = mm/in.

Process Connection	*Add to Length
3/4" NPT(M)	Shown
1" NPT(M)	Add $\frac{8.0}{.313}$
1-1/2" NPT(M)	Add $\frac{9.5}{.375}$
2" NPT(M)	

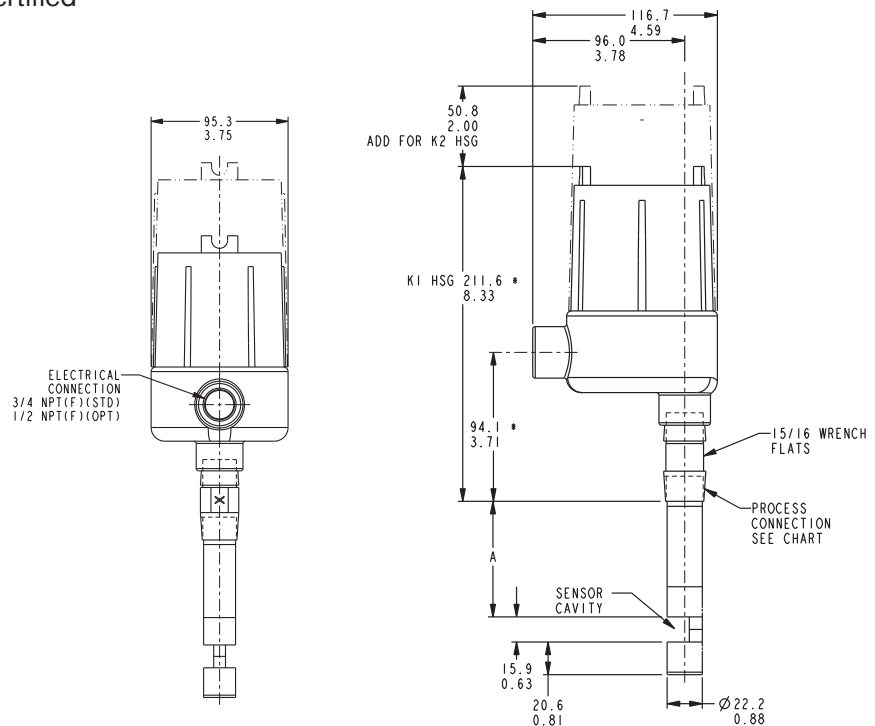

Type N Single Point (Threaded)

Drawing 0390000

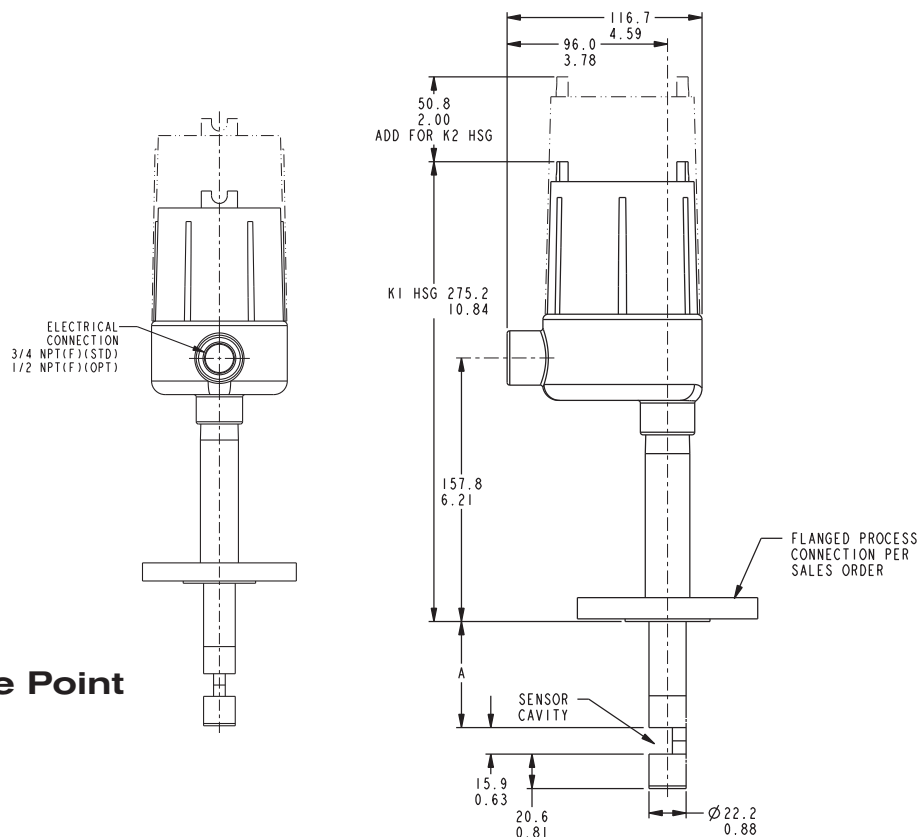

Type N Single Point (Flanged)

Drawing 0390025

Dimensions shown are for reference only. Contact the factory for certified dimension drawings.
 Linear = mm/in.

**Type N Dual Point
 (Threaded)**
 Drawing 0390029

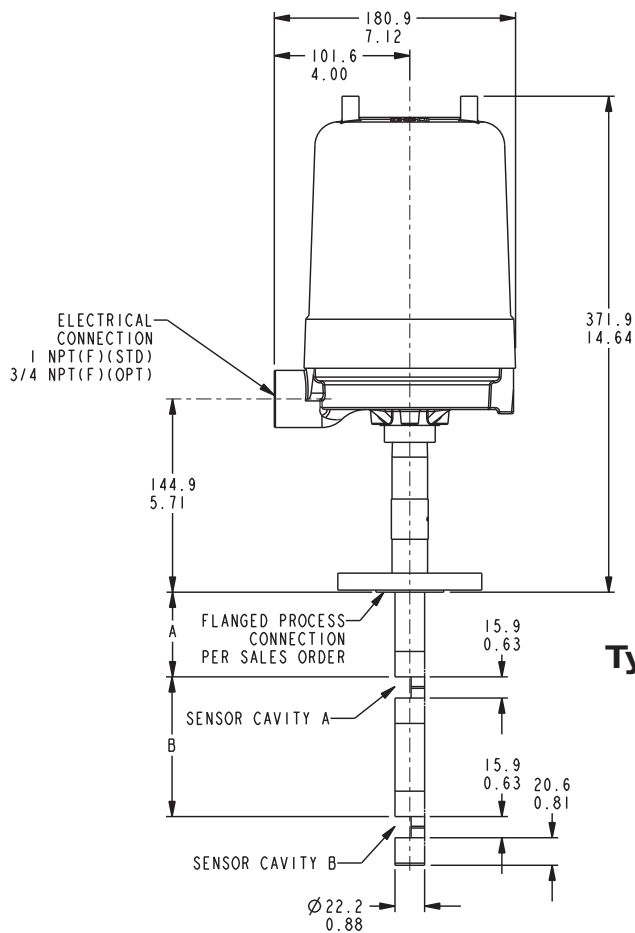
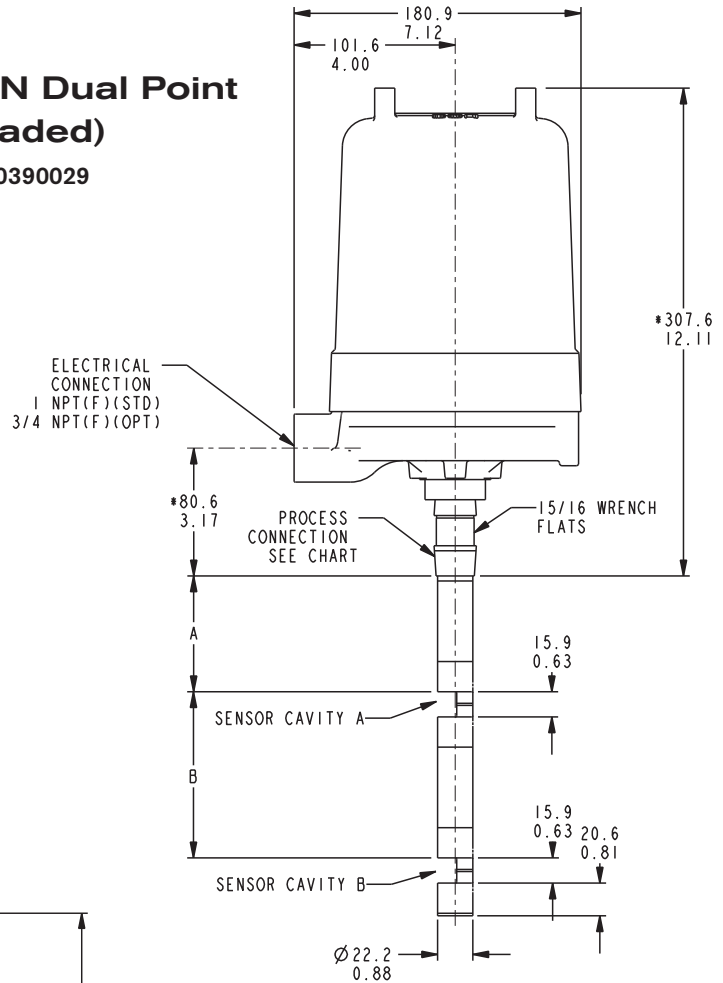

**Type N Dual Point
 (Flanged)**
 Drawing 0390030

Sensor Style	Weight
Types U & N	0.5 lbs. for first 6" 1 lb. (0.5 kg) for each additional 12"

Flange Weight and Pressure Rating

Process Connection	Add to Weight		Maximum Pressure Rating
	lbs.	kg	
3D	2	1.0	275 psig (19 bar)
3E	4	1.8	
3F	5	2.3	
3G	9	4	
3H	17	8	
3K	3	1.5	720 psig (50 bar)
3L	6	2.7	
3M	8	3.6	
3N	16	7.5	
3P	27	12.5	



MEASUREMENT AND CONTROL

SOR Inc. | Lenexa, KS USA | 913-888-2630 | Fax 913-888-0767 | SORInc.com

REGIONAL OFFICES

China

SOR China | Beijing, China | china@SORInc.com
+86 10 5820 8767 | Fax +86 10 5820 8770

Middle East

SOR Measurement & Control Equipment Trading DMCC | Dubai, UAE
middleeast@SORInc.com | +971 4 278 9632 | Fax + 1 913 312 3596