

IVSS INLINE VALVE SAMPLING SYSTEM



The SENSOR Inline Valve Sampling System (IVSS) fits directly into the process piping system without the need to utilize, or create, a pressure differential to collect a sample. It can be designed to fit into 1", 2" or 3" vertical or horizontal piping orientation. The IVSS can be configured to utilize a thread-in bottle or needles for a bottle with cap and septa.

Two Configurations Available

The IVSS can be configured with a wafer or inline flanges providing the ability to be installed in virtually any piping system.

The wafer configuration is designed to be sandwiched between two existing flanges. The inline version includes mating flanges on each end that can be specified to any required face-to-face dimension.

How Valve is Designed

The valve has been designed with the user in mind. The easy to use pull-type lever allows the operator to control the flow of the liquid into the bottle while taking a sample. Immediately after the handle is released the valve springs closed forming a tight seal and terminating the flow of sample collection.

Applications

The IVSS was designed for smaller batch processes, typically chemical facilities, where more specialty products are produced. These applications often require a dedicated sample collection system that ensures a homogeneous collection process and eliminates outside contamination of the media and/or exposure to the operator.



Features and Benefits

Spring-Loaded Handle	Valve automatically closed off after releasing the handle.
Weep Hole Above Packing	When packing begins to fail, weep hole provides early warning.
Interchangeable Adapter	Several types of adapters can be used to allow for various bottle types with thread-in or needle configuration.
Throttle Handle	Operator has the ability to control the bottle fill rate with the handle.
Lockable Handle with Insertion Pin	To perform maintenance or to prevent accidental opening when not intended to be used.
Wafer or Inline Type Design	The IVSS can fit in any new or existing piping configuration.
Body Materials	Standard is 316SS but available in HC276 to handle corrosive chemicals.

Product Specifications

Materials of Construction

Inline Flanged Valve	316LSS standard, HC276 optional
Wafer Valve	316LSS standard, HC276 optional
Threaded Bottle Adapter	PTFE
Process Needle	316SS standard, HC276 optional
Vent Needle	316SS standard, HC276 optional
O-Ring Material	Viton standard, optional Kalrez
Valve Packing Material	Teflon™ standard
Bottle Shroud	PVC, 2 oz. - 32 oz. standard (other sizes available)
Retaining Strap	Stainless Steel

Max Operating Pressure 232 psig

Max Operating Temperature 350°F

Optional Equipment

SENSOR Needle Evacuation System (NES)	Includes check valve, regulator, rotameter, pressure gauge, and block valve.
Emissions Filter	Canister with activated carbon for use when no vent to flare is available; also available with indication crystals which change color when filter media is saturated.
Bottle Enclosure	Available to house the bottle to protect the operator during collection and prevent outside contamination.
Kalrez® Seals	Kalrez® is offered to provide chemical compatibility when needed.
Secondary Isolation Valve	Available when double-block is required or desired.
Silconert Internal Coating	To prevent adsorption of collected media to the sample valve or needles.
Steam Tracing & Insulation	All components in contact with process are steam traced and insulated to prevent unwanted cooling.

Optional Equipment

CONCENTRIC Needle System

The CONCENTRIC Needle design combines the function of the 2-needle system in one concentric combination of two different sized needles, one within the other. Process travels through the inner needle into the bottle and the displaced air and vapors are vented back through the annulus between the two needles and plumbed to a safe area.



CONCENTRIC NEEDLE FEATURES

- Aligns the process and venting functions with the center of the sample bottle
- Can be ordered as an OPTION without changing the sample station design
- Can be supplied in the same materials as the dual needle system
- Can improve reliability of the sample station in the field, if utilized for the right applications
- Can be used with vials with crimp-on caps
- Can be used for small sample bottles (less than 1 oz.)

Process vent sizes
.065"/.109"
.083"/.148"
.109"/.203"

Thread-in versus needle adapter.

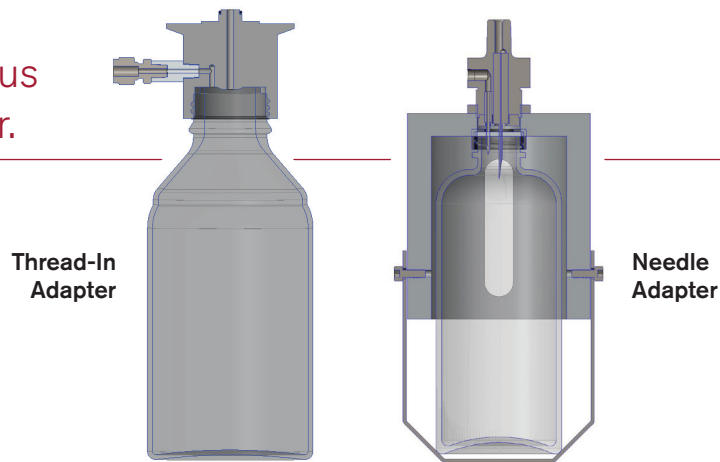

Dimensions

Wafer Valve

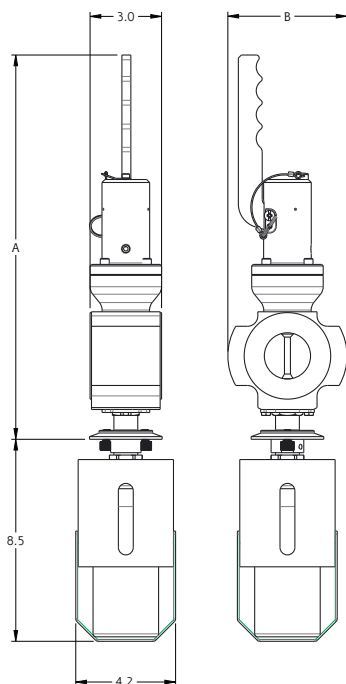

Inline Flanged Valve

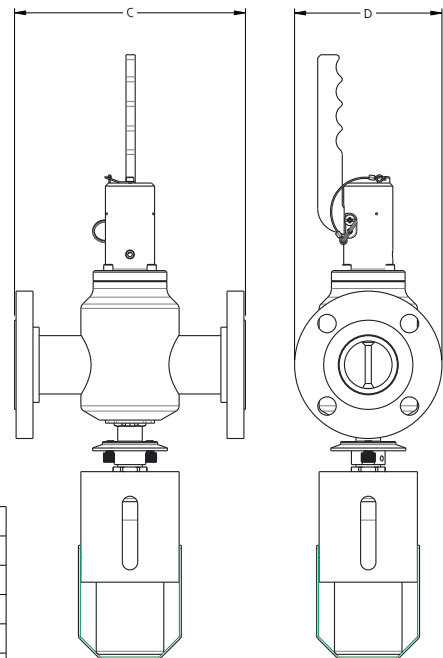

DIM	VALVE SIZE		
	1"	2"	3"
A	15.6"	16.1"	17.4"
B	4.3"	5.0"	6.0"
C	7.9"	9.4"	11.0"
D	4.3"	6.0"	7.5"

Inline Valve System Application Data Sheet

SKETCH **PIPING** or **APPLICATION** HERE



COMMENTS

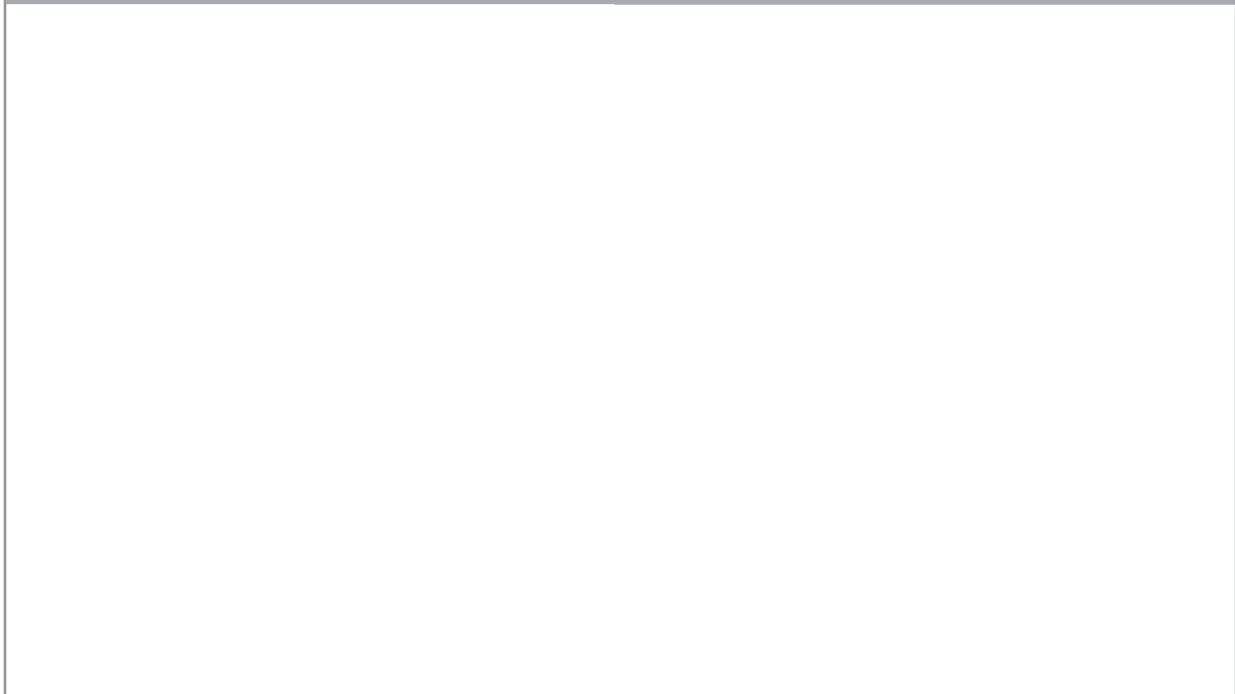

Form 1894 (04.23) ©SENSOR

Base Systems

SENSOR Sampling Systems are designed and manufactured for your specific needs. These customizable, high quality systems are required to manage quality, yields and other important aspects of chemical and hydrocarbon processes.



BBSS

[Basic Bottle Sampling System](#)

- Simple, flow-thru valve design
- Zero dead volume
- Replaceable process and vent needles
- Available with SENSOR Needle Evacuation System (NES)

PIBSS

[Pressure Isolating Bottle Sampling System](#)

- Guaranteed repeatable sample volume
- Zero dead volume
- Replaceable process and vent needles
- Suitable for high process pressures
- SENSOR Needle Evacuation System (NES) standard



LGSS & VSS

[Liquefied & Vapor Gas Sampling Systems](#)

- Safe, simple methodology for sampling high pressure liquefied gases and process gases
- Single handle operation
- Panel mounted pressure gauge
- Sight glass ensures safe cylinder outage on LGSS
- Ability to depressurize quick connects before removing cylinder



ISS

[Inline Sampling System](#)

- Available in wide variety of piping materials and end connections
- Suitable for high temperature, high viscosity service
- Available with open tube "stinger" or process needle
- Direct mount to process piping

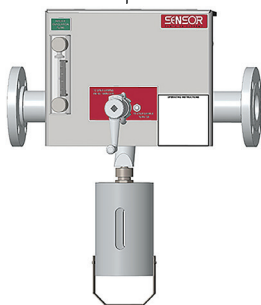
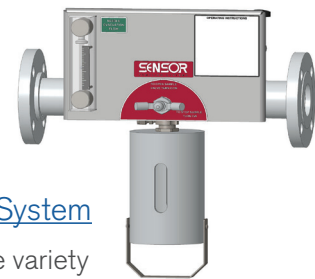

RSS

[RAM Sampling System](#)

- Available in wide variety of piping materials and end connections
- Suitable for high temperature, high viscosity service
- Available with open tube "stinger" or process needle
- Variety of connections to mate up to existing piping or vessel

HPSS

[Heavy Products Sampling System](#)

- Removable Cartridge Designed Valve allows easy maintenance without removing the entire Flanged Spool Assembly
- Steam Heated Dispense Tube ensures that any residual remains hot and fluidized until it can be purged
- Steam Purge after each sample collection eliminates the chance of plugging
- Condensate-free steam flush assembly with the use of a unique 3-way needle valve and steam trap
- Twist Lock Purge Adapter ensures residual material that is purged out is contained instead of spraying out inside the enclosure



Inline Valve Sampling System IVSS